

---

## UCD3138128A Highly-Integrated Digital Controller For Isolated Power

---

### 1 Features

- 128 kB Program Flash Derivative of UCD3138xA Family
  - 4-32 kB Program Flash Memory Banks
  - Supports Execution From 1 Bank, While Programming Another
  - Capability to Update Firmware Without Shutting Down the Power Supply
  - Additional Communication Ports Compared to the UCD3138xA (+1 SPI, +1 I2C)
  - Boot Flash Based Dual Memory Image Support for 'On the Fly' Firmware Updates
- Synchronous Rectifier Dead Time Optimization Peripheral to Use with UCD7138 Synchronous Rectifier Driver
- Digital Control of up to 3 Independent Feedback Loops
  - Dedicated PID Based Hardware
  - 2-pole/2-zero Configurable, Non-Linear Control
- Up to 16 MSPS Error A/D Converter (EADC)
  - Configurable Resolution (min: 1 mV/LSB)
  - Up to 8x Oversampling and Adaptive Sample Positioning
  - Hardware Based Averaging (up to 8x)
  - 14 bit Effective Reference DAC
- Up to 8 High Resolution Digital Pulse Width Modulated (DPWM) Outputs
  - 250 ps Pulse Width Resolution
  - 4 ns Frequency and Phase Resolution
  - Adjustable Phase Shift and Dead-bands
  - Cycle-by-Cycle Duty Cycle Matching
  - Up to 2 MHz Switching Frequency
- Configurable Trailing/Leading/Triangular Modulation
- RTC Support
- External Crystal Interface
- Configurable Feedback Control
  - Voltage, Average Current and Peak Current Mode Control
  - Constant Current, Constant Power
- Configurable FM, Phase Shift Modulation and PWM
- Fast, Automatic and Smooth Mode Switching
  - Frequency Modulation and PWM
  - Phase Shift Modulation and PWM
- High Efficiency and Light Load Management
  - Burst Mode and Ideal Diode Emulation
  - Synchronous Rectifier Soft On/Off
  - Low IC Standby Power
- Primary Side Voltage Sensing
- Current Share (Average and Master/Slave)
- Feature Rich Fault Protection Options
  - 7 Analog / 4 Digital Comparators,
  - Cycle-by-Cycle Current Limiting
  - Programmable Blanking Time and Fault Counting
  - External Fault Inputs
- Synchronization of DPWM Waveforms Between Multiple UCD3138x Devices
- 15 channel, 12 bit, 539 ksp/s General Purpose ADC
- Internal Temperature Sensor
- Fully Programmable High-Performance 31.25 MHz, 32-bit ARM7TDMI-S Processor
  - 128 kB Program Flash (4-32 kB Banks)
  - 2 kB Data Flash with ECC
  - 8 kB Data RAM
  - 8 kB Boot ROM Enables Firmware Boot-Load
- Communication Peripherals,
  - 2 - I<sup>2</sup>C/PMBus interfaces
  - 2 - UARTs, 1 - SPI
- UART Auto Baud Rate Adjustment
- Timer Capture with Selectable Input Pins
- 80-pin QFP Package
- Operating Temperature: –40°C to 125°C
- Debug Interface
  - Code Composer Studio with JTAG Interface
  - Fusion Digital Power Designer GUI Support



## 2 Applications

- Power Supplies and Telecom Rectifiers
- Power Factor Correction
- Isolated DC-DC Modules
- Phase Shifted Full Bridge with Peak Current Mode Control, LLC, HSFB, Forward

### Typical Applications and Tools

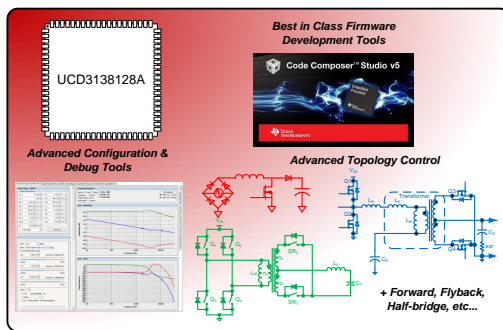

## 3 Description

The UCD3138xA is a digital power supply controller from Texas Instruments offering superior levels of integration and performance in a single chip solution. The UCD3138128A offers 128 kB of program flash memory in comparison to 32 kB in UCD3138A. and it also provides additional options for communication such as SPI and a second I<sup>2</sup>C/PMBus port. The availability of program Flash memory in multiple 32 kB banks enables designers to implement dual images of firmware (that is, one main image + one back-up image) in the device and provides the option to execute from either of the banks using appropriate algorithms. It also creates the unique opportunity for the processor to load a new program and subsequently execute that program without interrupting power delivery. This feature allows the end user to add new features to the power supply in the field while eliminating any down-time required to load the new program.

The flexible nature of the UCD3138xA family makes it suitable for a wide variety of power conversion applications. In addition, multiple peripherals inside the device have been specifically optimized to enhance the performance of AC/DC and isolated DC/DC applications and reduce the solution component count in the IT and network infrastructure space. The UCD3138xA family is a fully programmable solution offering customers complete control of their application, along with ample flexibility for many solutions. At the same time, TI is committed to simplifying our customer's development effort through offering best in class development tools, including application firmware, Code Composer Studio™ software development environment, and TI's Fusion Power Development GUI which enables customers to configure and monitor key system parameters.

At the core of the controller are the Digital Power Peripherals (DPP). Each DPP implements a high speed digital control loop consisting of a dedicated Error Analog to Digital Converter (EADC), a PID based 2 pole - 2 zero digital compensator and DPWM outputs with 250 ps pulse width resolution. The device also contains a 12-bit, 539 ksps general purpose ADC with up to 15 channels, timers, interrupt control, PMBus, I<sup>2</sup>C, SPI and UART communications ports. The device is based on a 32-bit ARM7TDMI-S RISC microcontroller that performs real-time monitoring, configures peripherals and manages communications. The ARM microcontroller executes its program out of programmable flash memory as well as on chip RAM and ROM.

In addition to the DPP, specific power management peripherals have been added to enable high efficiency across the entire operating range, high integration for increased power density, reliability, and lowest overall system cost and high flexibility with support for the widest number of control schemes and topologies. Such peripherals include: light load burst mode, synchronous rectification, LLC and phase shifted full bridge mode switching, input voltage feed forward, copper trace current sense, ideal diode emulation, constant current constant power control, synchronous rectification soft on and off, peak current mode control, flux balancing, secondary side input voltage sensing, high resolution current sharing, hardware configurable soft start with pre bias, as well as several other features. Topology support has been optimized for voltage mode and peak current mode controlled phase shifted full bridge, single and dual phase PFC, bridgeless PFC, hard switched full bridge and half bridge, active clamp forward converter, two switch forward converter and LLC half bridge and full bridge.

The UCD3138128A is a functional variant of the UCD3138 Digital Power Controller that includes significant improvements over the UCD3138. For a description of the complete changes made in the UCD3138128A, refer to UCD3138128A Migration Guide. The major improvements are:

- The General Purpose ADC has been improved for better accuracy and performance at extreme cold temperatures (–40°C).
- The UART peripheral has been modified to include a hardware based auto-baud rate adjustment feature.
- A new Synchronous Rectifier Dead Time Optimization hardware peripheral has been added. Benefits include:
  - Improved efficiency
  - Reduced synchronous rectifier voltage stresses
  - Shorter development cycle
- A Duty Cycle Read Function has been added to improve use in peak current mode.

#### Device Information<sup>(1)</sup>

PART NUMBER	PACKAGE	BODY SIZE (NOM)
UCD3138128A	TQFP (80)	12.00 mm x 12.00 mm

(1) For detailed ordering information please check the [Mechanical, Packaging, and Orderable Information](#) section at the end of this datasheet.

## Table of Contents

<b>1 Features</b> .....	<b>1</b>	9.2 Functional Block Diagram .....	21
<b>2 Applications</b> .....	<b>2</b>	9.3 Feature Description .....	22
<b>3 Description</b> .....	<b>2</b>	9.4 Device Functional Modes .....	50
<b>4 Revision History</b> .....	<b>4</b>	9.5 Register Maps .....	57
<b>5 Device Comparison</b> .....	<b>5</b>	<b>10 Applications and Implementation</b> .....	<b>60</b>
<b>6 Pin Configuration and Functions</b> .....	<b>7</b>	10.1 Application Information .....	60
<b>7 Specifications</b> .....	<b>9</b>	10.2 Typical Application .....	61
7.1 Absolute Maximum Ratings .....	9	<b>11 Power Supply Recommendations</b> .....	<b>72</b>
7.2 ESD Ratings .....	9	<b>12 Layout</b> .....	<b>72</b>
7.3 Recommended Operating Conditions .....	10	12.1 Device Grounding and Layout Guidelines .....	72
7.4 Thermal Information .....	10	12.2 Layout Examples .....	73
7.5 Electrical Characteristics .....	10	<b>13 Device and Documentation Support</b> .....	<b>74</b>
7.6 Timing Characteristics .....	13	13.1 Device Support .....	74
7.7 PMBus/SMBus/I <sup>2</sup> C Timing .....	14	13.2 Documentation Support .....	74
7.8 Typical Characteristics .....	15	13.3 Receiving Notification of Documentation Updates .....	76
7.9 Timing Diagrams .....	16	13.4 Trademarks .....	76
<b>8 Parametric Measurement Information</b> .....	<b>17</b>	13.5 Electrostatic Discharge Caution .....	76
8.1 Typical Clock Gating Power Savings .....	18	13.6 Glossary .....	76
<b>9 Detailed Description</b> .....	<b>19</b>	<b>14 Mechanical, Packaging, and Orderable Information</b> .....	<b>76</b>
9.1 Overview .....	19		

## 4 Revision History

NOTE: Page numbers for previous revisions may differ from page numbers in the current version.

<b>Changes from Original (June 2016) to Revision A</b>	<b>Page</b>
• Added two temperature ranges to the Internal oscillator frequency section. ....	13
• Changed <a href="#">Figure 15</a> .....	29
• Changed <a href="#">Figure 35</a> to include DTC Adjustment .....	51
• Changed capacitor from RESET to ground value from 0.22 $\mu$ F to 2.2 $\mu$ F. ....	72
• Added updated V33 slew rate values in the Device Grounding and Layout Guidelines section. ....	72
• Added bullet on unused GPIO pins .....	72
• Changed "A" to part number .....	73

## 5 Device Comparison

**Table 1. Product Family Comparison**

FEATURE	UCD						
	3138 3138A RHA/RMH	3138064 3138064A RMH	3138 3138A RGC	3138064 3138064A RGC	3138064 RGZ	3138128 3138128A PFC	3138A64 PFC
Package Offering	40 Pin QFN (6mm x 6mm)	40 Pin QFN (6mm x 6mm)	64 Pin QFN (9mm x 9mm)	64 Pin QFN (9mm x 9mm)	48 Pin QFN (7mm x 7mm)	80 Pin QFP (14mm x 14mm) (Includes leads)	80 Pin QFP (14mm x 14mm) (Includes leads)
ARM7TDMI-S Core Processor	31.25 MHz	31.25 MHz	31.25 MHz	31.25 MHz	31.25 MHz	31.25 MHz	31.25 MHz
High Resolution DPWM Outputs (250ps Resolution)	8	8	8	8	8	8	8
Number of High Speed Independent Feedback Loops (# Regulated Output Voltages)	3	3	3	3	3	3	3
12-bit, 256kps, General Purpose ADC Channels	7	7	14	14	9	15	15
Digital Comparators at ADC Outputs	4	4	4	4	4	4	4
Flash Memory (Program)	32 kB	64 kB	32 kB	64 kB	64 kB	128 kB	64 kB
Number of Memory 32kB Flash Memory Banks	1	2	1	2	2	4	Only 1 bank of 64 kB Flash available
Flash Memory (Data)	2 kB	2 kB	2 kB	2 kB	2 kB	2 kB	2 kB
RAM	4 kB	4 kB	4 kB	4 kB	4 kB	8 kB	8 kB
Programmable Fault Inputs	1 + 2 <sup>(1)</sup>	1 + 2 <sup>(1)</sup>	4	2 + 2 <sup>(1)</sup>	1 + 2 <sup>(1)</sup>	4	4
High Speed Analog Comparators with Cycle-by-Cycle Current Limiting	6	6	7	7	6	7	7
UART (SCI)	1 <sup>(1)</sup>	1 <sup>(1)</sup>	2	2	2	2	2
PMBus/I <sup>2</sup> C	1	1	1	1	1	1	1
Additional I <sup>2</sup> C	0	0	0	1 <sup>(1)</sup>	1 <sup>(1)</sup>	1	1
SPI	0	0	0	1 <sup>(1)</sup>	1 <sup>(1)</sup>	1	1
Timers	4 (16 bit) and 1 (24 bit)	4 (16 bit) and 1 (24 bit)	4 (16 bit) and 1 (24 bit)	4 (16 bit) and 1 (24 bit)	4 (16 bit) and 1 (24 bit)	4 (16 bit) and 2 (24 bit)	4 (16 bit) and 2 (24 bit)
Timer PWM Outputs	1 <sup>(1)</sup>	1 <sup>(1)</sup>	2	2	1 <sup>(1)</sup>	4	4
Timer Capture Inputs	2 <sup>(1)</sup>	2 <sup>(1)</sup>	1 + 3 <sup>(1)</sup>	1 + 3 <sup>(1)</sup>	2 <sup>(1)</sup>	2 + 2 <sup>(1)</sup>	2 + 2 <sup>(1)</sup>
Total Digital GPIOs	18	18	30	30	24	43	43
External Interrupts	0	0	1	1	0	1	1
External Crystal Clock Support	no	no	no	no	no	Yes (pins #61, 62)	Yes (pins #61, 62)
Peak Current Mode Control	EADC2 Only	All EADC channels	EADC Only	All EADC channels	All EADC Channels	All EADC Channels	All EADC Channels

(1) Represents an alternate pin out that is programmable via firmware.

**Table 2. Device Feature Information**

FEATURE	UCD3138128A 80 PIN
ARM7TDMI-S Core Processor	31.25 MHz
High Resolution DPWM Outputs (250ps Resolution)	8
Number of High Speed Independent Feedback Loops (# Regulated Output Voltages)	3
12-bit, 539 ksps, General Purpose ADC Channels	15
Digital Comparators at ADC Outputs	4
Flash Memory (Program)	128 kB
Flash Memory (Data)	2 kB
Flash Security	√
RAM	8 kB
DPWM Switching Frequency	up to 2 MHz
Programmable Fault Inputs	4
High Speed Analog Comparators with Cycle-by-Cycle Current Limiting	7
UART (SCI)	2
PMBus	1
I <sup>2</sup> C	1
SPI	1
Timers	4 (16 bit) and 2 (24 bit)
Timer PWM Outputs	4
Timer Capture Inputs	2
Watchdog	√
On Chip Oscillator	√
Power-On Reset and Brown-Out Detector	√
Sync IN and Sync OUT Functions	√
Total GPIO (includes all pins with multiplexed functions such as, DPWM, Fault Inputs, SCI, etc.)	43
External Interrupts	1

## 6 Pin Configuration and Functions

PFC Package  
80 Pins (TQFP)  
Top View

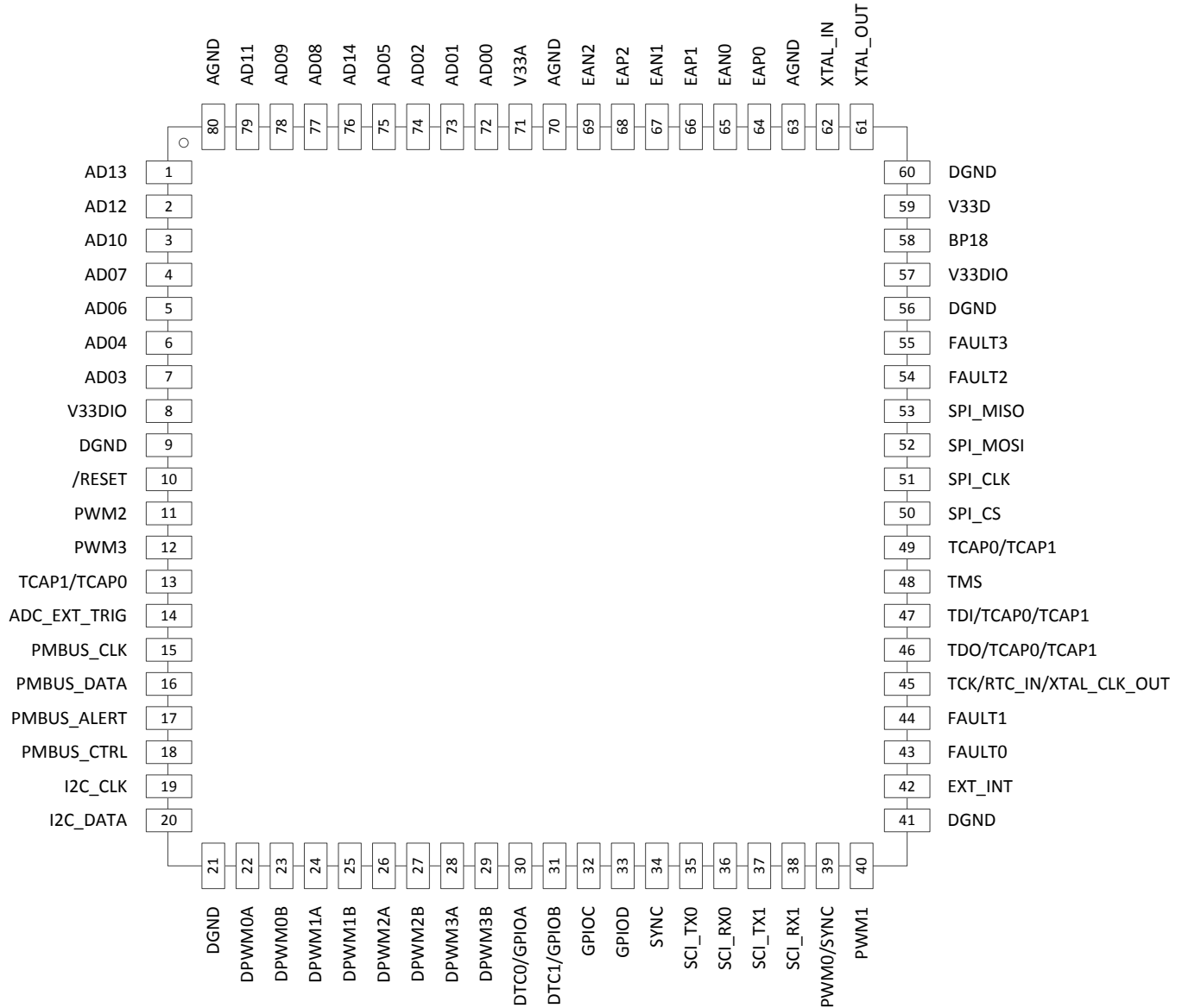

Additional pin functionality is specified in the following table.

### Pin Functions

PIN	NAME	PRIMARY ASSIGNMENT	ALTERNATE ASSIGNMENT		CONFIGURABLE AS A GPIO?
			NO. 1	NO. 2	
1	AD13	12-bit ADC, Ch 13, comparator E, I-share	DAC output		
2	AD12	12-bit ADC, Ch 12			
3	AD10	12-bit ADC, Ch 10			
4	AD07	12-bit ADC, Ch 7, Connected to comparator F and reference to comparator G	DAC output		
5	AD06	12-bit ADC, Ch 6, Connected to comparator F	DAC output		
6	AD04	12-bit ADC, Ch 4, Connected to comparator D	DAC output		
7	AD03	12-bit ADC, Ch 3, Connected to comparator B and C			
8	V33DIO	Digital I/O 3.3V core supply			

**Pin Functions (continued)**

PIN	NAME	PRIMARY ASSIGNMENT	ALTERNATE ASSIGNMENT		CONFIGURABLE AS A GPIO?
			NO. 1	NO. 2	
9	DGND	Digital ground			
10	RESET	Device Reset Input, active low			
11	PWM2	General purpose PWM 2			Yes
12	PWM3	General purpose PWM 3			Yes
13	TCAP1	Timer Capture Input	TCAP0		Yes
14	ADC_EXT_TRIG	ADC conversion external trigger input			Yes
15	PMBUS_CLK	PMBUS Clock (Open Drain)			Yes
16	PMBUS_DATA	PMBus data (Open Drain)			Yes
17	PMBUS_ALERT	PMBus Alert (Open Drain)			Yes
18	PMBUS_CTRL	PMBus Control (Open Drain)			Yes
19	I2C_CLK	I2C Clock			Yes
20	I2C_DATA	I2C Data			Yes
21	DGND	Digital ground			
22	DPWM0A	DPWM 0A output			Yes
23	DPWM0B	DPWM 0B output			Yes
24	DPWM1A	DPWM 1A output			Yes
25	DPWM1B	DPWM 1B output			Yes
26	DPWM2A	DPWM 2A output			Yes
27	DPWM2B	DPWM 2B output			Yes
28	DPWM3A	DPWM 3A output			Yes
29	DPWM3B	DPWM 3B output			Yes
30	DTC0	Synchronous Rectifier dead time optimization control input 0	GPIOA		Yes
31	DTC1	Synchronous Rectifier dead time optimization control input 1	GPIOB		Yes
32	GPIOC	General purpose IO C			Yes
33	GIPOD	General purpose IO D			Yes
34	SYNC	DPWM Synchronize pin			Yes
35	SCI_TX0	SCI TX 0			Yes
36	SCI_RX0	SCI RX 0			Yes
37	SCI_TX1	SCI TX 1			Yes
38	SCI_RX1	SCI RX 1			Yes
39	PWM0	General purpose PWM 0	SYNC		Yes
40	PWM1	General purpose PWM 1			Yes
41	DGND	Digital ground			
42	EXT_INT	External Interrupt			Yes
43	FAULT0	External fault input 0			Yes
44	FAULT1	External fault input 1			Yes
45	TCK <sup>(1)</sup>	JTAG test clock. It is recommended that this pin is pulled LOW on the target.	RTC_IN	XTAL_CLK_OUT	Yes
46	TDO <sup>(1)</sup>	JTAG test data output. It is recommended that this pin is pulled HIGH on the target.	TCAP0	TCAP1	Yes
47	TDI <sup>(1)</sup>	JTAG test data input. It is recommended that this pin is pulled HIGH on the target.	TCAP0	TCAP1	Yes
48	TMS <sup>(1)</sup>	JTAG test mode select. This pin must be pulled HIGH on the target so that the effect of any spurious TCKs when there is no connection is benign.			Yes
49	TCAP0	Timer Capture Input	TCAP1		Yes
50	SPI_CS	SPI Chip Select			Yes
51	SPI_CLK	SPI Clock			Yes
52	SPI_MOSI	SPI Master Output Slave Input			Yes
53	SPI_MISO	SPI Master Input Slave Output			Yes
54	FAULT2	External fault input 2			Yes
55	FAULT3	External fault input 3			Yes
56	DGND	Digital ground			
57	V33DIO	Digital I/O 3.3-V core supply			
58	BP18	1.8V Bypass (For internal use only, do not load)			
59	V33D	Digital 3.3-V core supply			

(1) Fusion Digital Power based debug tools are recommended instead of JTAG.

### Pin Functions (continued)

PIN	NAME	PRIMARY ASSIGNMENT	ALTERNATE ASSIGNMENT		CONFIGURABLE AS A GPIO?
			NO. 1	NO. 2	
60	DGND	Digital ground			
61	XTAL_OUT	Crystal oscillator input			
62	XTAL_IN	Crystal oscillator output			
63	AGND	Analog ground			
64	EAP0	Channel #0, differential analog voltage, positive input			
65	EAN0	Channel #0, differential analog voltage, negative input			
66	EAP1	Channel #1, differential analog voltage, positive input			
67	EAN1	Channel #1, differential analog voltage, negative input			
68	EAP2	Channel #2, differential analog voltage, positive input			
69	EAN2	Channel #2, differential analog voltage, negative input			
70	AGND	Analog ground			
71	V33A	Analog 3.3V supply			
72	AD00	12-bit ADC, Ch 0, Connected to current source			
73	AD01	12-bit ADC, Ch 1, Connected to current source			
74	AD02	12-bit ADC, Ch 2, Connected to comparator A, I-share			
75	AD05	12-bit ADC, Ch 5			
76	AD14	12-bit ADC, Ch 14			
77	AD08	12-bit ADC, Ch 8			
78	AD09	12-bit ADC, Ch 9			
79	AD11	12-bit ADC, Ch 11			
80	AGND	Analog ground			

## 7 Specifications

### 7.1 Absolute Maximum Ratings<sup>(1)</sup>

over operating free-air temperature range (unless otherwise noted)

		VALUE		UNIT
		MIN	MAX	
Voltage	V33D to DGND	-0.3	3.8	V
	V33DIO to DGND	-0.3	3.8	V
	V33A to AGND	-0.3	3.8	V
	BP18 to DGND	-0.3	2.5	V
	Ground difference,  DGND – AGND		0.3	V
	Voltage applied to any pin, excluding AGND <sup>(2)</sup>	-0.3	3.8	V
Junction Temperature, T <sub>J</sub>		-40	125	°C
Storage temperature range, T <sub>stg</sub>		-55	150	°C

(1) Stresses beyond those listed under *Absolute Maximum Ratings* may cause permanent damage to the device. These are stress ratings only, which do not imply functional operation of the device at these or any other conditions beyond those indicated under *Recommended Operating Conditions*. Exposure to absolute-maximum-rated conditions for extended periods may affect device reliability.

(2) Referenced to DGND

### 7.2 ESD Ratings

V <sub>(ESD)</sub>	Electrostatic discharge		VALUE	UNIT
		Human body model (HBM), per ANSI/ESDA/JEDEC JS-001, all pins <sup>(1)</sup>	±2000	V
		Charged device model (CDM), per JEDEC specification JESD22-C101, all pins <sup>(2)</sup>	±500	

(1) JEDEC document JEP155 states that 500-V HBM allows safe manufacturing with a standard ESD control process.

(2) JEDEC document JEP157 states that 250-V CDM allows safe manufacturing with a standard ESD control process.

### 7.3 Recommended Operating Conditions

Over operating free-air temperature range (unless otherwise noted)

		MIN	TYP	MAX	UNIT
Digital power	V33D	3.0	3.3	3.6	V
Digital I/O power	V33DIO	3	3.3	3.6	V
Analog power	V33A	3	3.3	3.6	V
Digital power	BP18	1.6	1.8	2	V
Junction temperature, $T_J$		-40		125	°C

### 7.4 Thermal Information

THERMAL METRIC <sup>(1)</sup>		TQFP (QFN)	UNIT
		80-PIN	
$R_{\theta JA}$	Junction-to-ambient thermal resistance	47.8	°C/W
$R_{\theta Jtop}$	Junction-to-case (top) thermal resistance	7.8	
$R_{\theta JB}$	Junction-to-board thermal resistance	24.4	
$\Psi_{JT}$	Junction-to-top characterization parameter	0.2	
$\Psi_{JB}$	Junction-to-board characterization parameter	24.0	
$R_{\theta Jcbot}$	Junction-to-case (bottom) thermal resistance	N/A	

(1) For more information about traditional and new thermal metrics, see the [Semiconductor and IC Package Thermal Metrics](#) application report, .

### 7.5 Electrical Characteristics

 V33A = V33D = V33DIO = 3 V to 3.6 V; 1  $\mu$ F from BP18 to DGND,  $T_J$  = -40°C to 125°C (unless otherwise noted)

PARAMETER	TEST CONDITION	MIN	TYP	MAX	UNIT
<b>SUPPLY CURRENT</b>					
I33A <sup>(1)</sup>	Measured on V33A. The device is powered up but all ADC12 and EADC sampling is disabled		7.5		mA
I33DIO <sup>(1)</sup>	All GPIO and communication pins are open		0.35		mA
I33D <sup>(1)</sup>	ROM program execution		69		mA
I33	The device is in ROM mode with all DPWMs enabled and switching at 2 MHz. The DPWMs are all unloaded.		90	100	mA
<b>ERROR ADC INPUTS EAP, EAN</b>					
EAP – AGND <sup>(1)</sup>		-0.15		1.998	V
EAP – EAN <sup>(1)</sup>		-0.256		1.848	V
Typical error range <sup>(1)</sup>	AFE = 0			248	mV
EAP – EAN Error voltage digital resolution	AFE = 3	0.8	1	1.25	mV
	AFE = 2	1.7	2	2.4	mV
	AFE = 1	3.55	4	4.5	mV
	AFE = 0	6.90	8	9.10	mV
$R_{EA}$	Input impedance <sup>(1)</sup> (See <a href="#">Figure 11</a> )	AGND reference	0.5		M $\Omega$
$I_{OFFSET}$	Input offset current <sup>(1)</sup> (See <a href="#">Figure 11</a> )	EADC is in idle state	-5	5	$\mu$ A
EADC Offset	Input voltage = 0 V at AFE = 0	-20		20	mV
	Input voltage = 0 V at AFE = 1	-10		10	mV
	Input voltage = 0 V at AFE = 2	-6		6	mV
	Input voltage = 0 V at AFE = 3	-4		4	mV

(1) Characterized by design and not production tested.

## Electrical Characteristics (continued)

V33A = V33D = V33DIO = 3 V to 3.6 V; 1  $\mu$ F from BP18 to DGND,  $T_J = -40^\circ\text{C}$  to  $125^\circ\text{C}$  (unless otherwise noted)

PARAMETER		TEST CONDITION	MIN	TYP	MAX	UNIT
Sample Rate <sup>(1)</sup>					15.62 5	MHz
Analog Front End Amplifier Bandwidth <sup>(1)</sup>				100		MHz
A <sub>0</sub>	Gain <sup>(1)</sup>	See <a href="#">Figure 12</a>		1		V/V
	Minimum output voltage				25	mV
<b>EADC DAC</b>						
DAC range			0		1.6	V
VREF DAC reference resolution		10 bit, No dithering enabled		1.56		mV
VREF DAC reference resolution <sup>(1)</sup>		With 4 bit dithering enabled		97.6		$\mu$ V
INL	Ensured INL		-1.5		1.5	LSB
	Typical INL ( $T_J = 25^\circ\text{C}$ , V33A = V33D = V33DIO = 3.3 V)			-0.4/+0.7		LSB
DNL	Guaranteed DNL		-2.0		1	LSB
	Typical DNL ( $T_J = 25^\circ\text{C}$ , V33A = V33D = V33DIO = 3.3 V)			-0.4/+0.3		LSB
DAC reference voltage			1.58		1.61	V
<b>ADC12</b>						
I <sub>BIAS</sub>	Bias current for PMBus address pins		9.5		10.5	$\mu$ A
Measurement range for voltage monitoring			0		2.5	V
Internal ADC reference voltage			2.475	2.500	2.525	V
Change in Internal ADC reference from 25°C reference voltage <sup>(1)</sup>		25°C to -40°C		-2.36		mV
		25°C to 125°C		-5.45		
ADC12 INL integral nonlinearity, end point <sup>(1)</sup>		ADC_SAMPLING_SEL = 0 or 7 for all ADC12 data	-3.9	-2.5/2.2	4.5	LSB
ADC12 INL integral nonlinearity, best fit line <sup>(1)</sup>			-2.4	-1.6/1.7	2.9	LSB
ADC12 DNL differential nonlinearity <sup>(1)</sup>			-1.0	-0.6/+2.6	3.8	LSB
ADC Zero Scale Error			-5		5	mV
ADC Full Scale Error			-30		30	mV
Input bias		2.5 V applied to pin			200	nA
Input leakage resistance <sup>(1)</sup>		ADC_SAMPLING_SEL = 0		2		M $\Omega$
		ADC_SAMPLING_SEL = 7		1		M $\Omega$
Input Capacitance <sup>(1)</sup>				10		pF
<b>DIGITAL INPUTS/OUTPUTS<sup>(2)</sup></b>						
V <sub>OL</sub>	Low-level output voltage <sup>(3)(4)</sup>	I <sub>OH</sub> = 4 mA, V33DIO = 3 V			DGND + 0.25	V
V <sub>OH</sub>	High-level output voltage <sup>(3)</sup>	I <sub>OH</sub> = -4 mA, V33DIO = 3 V	V33DIO - 0.6			V
V <sub>IH</sub>	High-level input voltage	V33DIO = 3 V	2.1			V
V <sub>IL</sub>	Low-level input voltage	V33DIO = 3 V			1.1	V
I <sub>OH</sub>	Output sinking current				4	mA
I <sub>OL</sub>	Output sourcing current		-4			mA
<b>SYSTEM PERFORMANCE</b>						
I <sub>SHARE</sub>	Current share current source (See <a href="#">Figure 34</a> )		238		259	$\mu$ A

(2) On the 40 pin package V33DIO is connected to V33D internally.

(3) The maximum total current, I<sub>OHmax</sub> and I<sub>OLmax</sub> for all outputs combined, should not exceed 12 mA to hold the maximum voltage drop specified. Maximum sink current per pin = -6 mA at V<sub>OL</sub>; maximum source current per pin = 6 mA at V<sub>OH</sub>.

(4) DPWM outputs are low after reset. Other GPIO pins are configured as inputs after reset.

**Electrical Characteristics (continued)**

 V33A = V33D = V33DIO = 3 V to 3.6 V; 1  $\mu$ F from BP18 to DGND,  $T_J = -40^\circ\text{C}$  to  $125^\circ\text{C}$  (unless otherwise noted)

PARAMETER		TEST CONDITION	MIN	TYP	MAX	UNIT
$R_{\text{SHARE}}$	Current share resistor (See <a href="#">Figure 34</a> )		9.6		10.4	$k\Omega$
<b>POWER ON RESET AND BROWN OUT (V33A PIN)</b>						
V <sub>GH</sub>	Voltage good High	See <a href="#">Figure 9</a>	2.302	2.53	2.836	V
V <sub>GL</sub>	Voltage good Low		2.248	2.48	2.781	V
V <sub>res</sub>	Voltage at which I <sub>Reset</sub> signal is valid <sup>(1)</sup>		0.8			V
	Brownout	Internal signal warning of brownout conditions	2.774	2.9	3.077	V
<b>TEMPERATURE SENSOR</b>						
V <sub>TEMP</sub>	Voltage range of sensor <sup>(1)</sup>		1.46		2.44	V
	Voltage resolution <sup>(1)</sup>	Volts/ $^\circ\text{C}$		6.3		mV/ $^\circ\text{C}$
	Temperature resolution <sup>(1)</sup>	Degree C per bit		0.0969		$^\circ\text{C}/\text{LSB}$
	Accuracy <sup>(1)(5)</sup>	$-40^\circ\text{C}$ to $125^\circ\text{C}$	-10	$\pm 5$	10	$^\circ\text{C}$
	Temperature range <sup>(1)</sup>	$-40^\circ\text{C}$ to $125^\circ\text{C}$	-40		125	$^\circ\text{C}$
I <sub>TEMP</sub>	Current draw of sensor when active <sup>(1)</sup>			30		$\mu\text{A}$
V <sub>AMB</sub>	Ambient temperature	Trimmed $25^\circ\text{C}$ reading	1.858	1.9	1.954	V
<b>ANALOG COMPARATOR</b>						
DAC	Reference DAC Range <sup>(1)</sup>		0.019		2.5	V
	Reference voltage		2.478	2.5	2.513	V
	Bits			7		bits
	INL <sup>(1)</sup>		-0.5		0.21	LSB
	DNL <sup>(1)</sup>		0.06		0.12	LSB
	Offset		-5.5		19.5	mV
	Reference DAC buffered output load <sup>(6)</sup>		-0.5		1	mA
	Buffer offset (-0.5 mA)	$0.156\text{ V} < \text{DAC} < 2.363\text{ V}$	-10		10	mV
	Buffer offset (1.0 mA)	$0.059\text{ V} < \text{DAC} < 2.305\text{ V}$	-10		10	mV
<b>RTC INTERFACE</b>						
f <sub>RTC</sub>	RTC external input frequency <sup>(7)</sup>			10		MHz

(5) Ambient temperature offset value from the TEMPSENCTRL register should be used to meet accuracy.

(6) Available from reference DACs for comparators D, E, F and G.

(7) Performance dependent on selected external components. The maximum frequency should be no more than 12 MHz.

## 7.6 Timing Characteristics

V33A = V33D = V33DIO = 3.0 V to 3.6 V; 1  $\mu$ F from BP18 to DGND,  $T_J = -40^\circ\text{C}$  to  $125^\circ\text{C}$  (unless otherwise noted)

PARAMETER		TEST CONDITION	MIN	TYP	MAX	UNIT
<b>EADC DAC</b>						
t	Settling Time <sup>(1)</sup>	From 10% to 90%		250		ns
<b>ADC12</b>						
	ADC single sample conversion time <sup>(1)</sup>	ADC_SAMPLING_SEL= 0		3.9		$\mu$ s
	ADC single sample conversion time <sup>(1)</sup>	ADC_SAMPLING_SEL= 7		1..9		$\mu$ s
<b>SYSTEM PERFORMANCE</b>						
	Processor master clock (MCLK)			31.25		MHz
t <sub>Delay</sub>	Digital filter delay <sup>(2)</sup>				6	MCLKs
f <sub>(PCLK)</sub>	Internal oscillator frequency	-40°C to +125°C	240	250	260	MHz
		-5°C to +85°C	245	250	255	MHz
TWD	Watchdog time out range <sup>(1)</sup>	Total time is: TWD x (WDCTRL.PERIOD+1)	12.02	13.08	13.65	ms
	Time to disable DPWM output based on active FAULT pin signal <sup>(1)</sup>	High level on FAULT pin		80		ns
	Flash Read			1		MCLKs
	Retention period of flash content (data retention and program)	T <sub>J</sub> = 25°C	100			years
	Program time to erase one page or block in data flash or program flash			20		ms
	Program time to write one word in program flash			50		$\mu$ s
	Program time to write one word in data flash			40		$\mu$ s
	Sync-in/sync-out pulse width <sup>(1)</sup>	Sync pin		256		ns
<b>POWER ON RESET AND BROWN OUT (V33A pin, See Figure 9)</b>						
t <sub>POR</sub> <sup>(1)</sup>		Time delay after power is good or RESET* relinquished		1		ms
t <sub>EXC1</sub>	The time it takes from the device to exit a reset state and begin executing the boot flash. <sup>(1)</sup>	I <sub>RESET</sub> goes from a low state to a high state. This is approximately equivalent to toggling the external reset pin from low to high state.		0.5		ms
t <sub>EXC2</sub>	The time it takes from the device to exit a reset state and begin executing program flash bank 0 (32 kB). <sup>(1)</sup>	I <sub>RESET</sub> goes from a low state to a high state. This is approximately equivalent to toggling the external reset pin from low to high state.		3		ms
t <sub>EXCT</sub>	The time it takes from the device to exit a reset state and begin executing the total program flash (64 kB). <sup>(1)</sup>	I <sub>RESET</sub> goes from a low state to a high state. This is approximately equivalent to toggling the external reset pin from low to high state.		6		ms
<b>TEMPERATURE SENSOR<sup>(1)</sup></b>						
t <sub>ON</sub> <sup>(1)</sup>		Turn on time / settling time of sensor		100		$\mu$ s
<b>ANALOG COMPARATOR</b>						
	Time to disable DPWM output based on 0 V to 2.5 V step input on the analog comparator. <sup>(1)</sup>			90	150	ns

(1) Characterized by design and not production tested.

(2) Time from close of error ADC sample window to time when digitally calculated control effort (duty cycle) is available. This delay, which has no variation associated with it, must be accounted for when calculating the system dynamic response.

## 7.7 PMBus/SMBus/I<sup>2</sup>C Timing

The timing characteristics and timing diagram for the communications interface that supports I<sup>2</sup>C, SMBus, and PMBus in Slave or Master mode are shown in [PMBus/SMBus/I<sup>2</sup>C Timing, Figure 6](#), and [Figure 7](#). The numbers in [PMBus/SMBus/I<sup>2</sup>C Timing](#) shows that the device supports standard (100 kHz), fast (400 kHz), and fast-mode plus (1 MHz) speeds. <sup>(1)</sup>

PARAMETER	TEST CONDITIONS	100 kHz Class		400 kHz Class		1 MHz Class <sup>(2)</sup>		UNIT		
		MIN	MAX	MIN	MAX	MIN	MAX			
Typical values at T <sub>A</sub> = 25 °C and VCC = 3.3 V (unless otherwise noted)										
f <sub>SMB</sub>	SMBus/PMBus operating frequency	Slave mode, SMBC 50% duty cycle		10	100	10	400	10	1000	kHz
f <sub>I2C</sub>	I <sup>2</sup> C operating frequency	Slave mode, SCL 50% duty cycle		10	100	10	400	10	1000	kHz
t <sub>(BUF)</sub>	Bus free time between start and stop			4.7		1.3		0.5		μs
t <sub>(HD:STA)</sub>	Hold time after (repeated) start			4		0.6		0.26		μs
t <sub>(SU:STA)</sub>	Repeated start setup time			4.7		0.6		0.26		μs
t <sub>(SU:STO)</sub>	Stop setup time			4		0.6		0.26		μs
t <sub>(HD:DAT)</sub>	Data hold time	Receive mode		0		0		0		ns
t <sub>(SU:DAT)</sub>	Data setup time			250		100		50		ns
t <sub>(TIMEOUT)</sub>	Error signal/detect			25	35	25	35	25	35	ms
t <sub>(LOW)</sub>	Clock low period			4.7		1.3		0.5		μs
t <sub>(HIGH)</sub>	Clock high period			4	50	0.6	50	0.26	50	μs
t <sub>(LOW:SEXT)</sub>	Cumulative clock low slave extend time				25		25		25	ms
t <sub>r</sub>	Clock/data fall time	Rise time t <sub>r</sub> = (V <sub>ILmax</sub> – 0.15) to (V <sub>IHmin</sub> + 0.15)		20 + 0.1 C <sub>b</sub>	300	20 + 0.1 C <sub>b</sub>	300	20 + 0.1 C <sub>b</sub>	120	ns
t <sub>f</sub>	Clock/data rise time	Fall time t <sub>f</sub> = 0.9 VDD to (V <sub>ILmax</sub> – 0.15)		20 + 0.1 C <sub>b</sub>	1000	20 + 0.1 C <sub>b</sub>	300	20 + 0.1 C <sub>b</sub>	120	ns
C <sub>b</sub>	Total capacitance of one bus line						400			pF

(1) Values dependent on bus pull up resistor selection and are not ATE tested.

(2) Characterized by design and not production tested.

### 7.8 Typical Characteristics

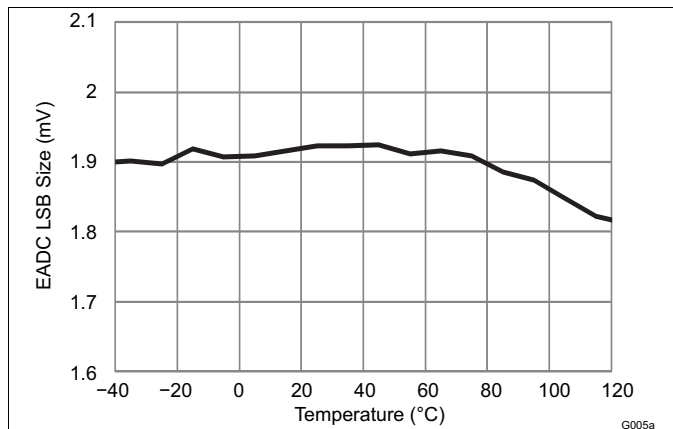

Figure 1. EADC LSB Size With 4x Gain (mV) vs. Temperature

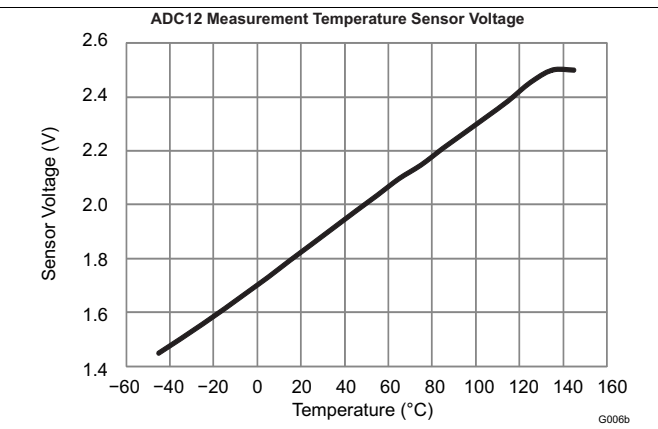

Figure 2. ADC12 Measurement Temperature Sensor Voltage vs. Temperature

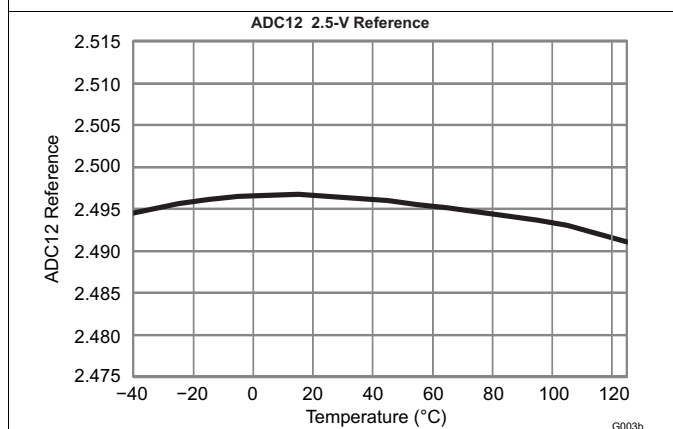

Figure 3. ADC12 2.5-V Reference vs. Temperature

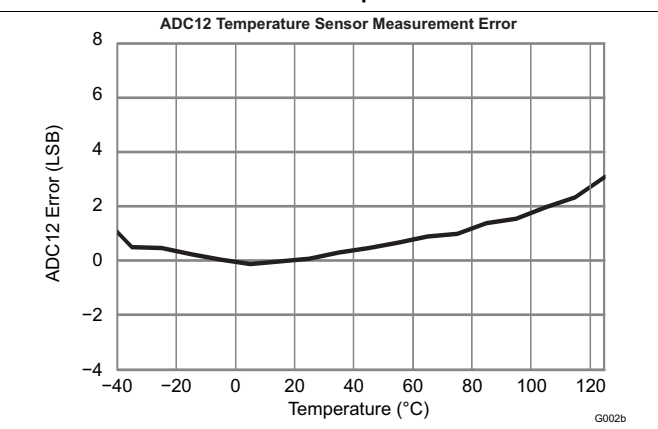

Figure 4. ADC12 Temperature Sensor Measurement Error vs. Temperature

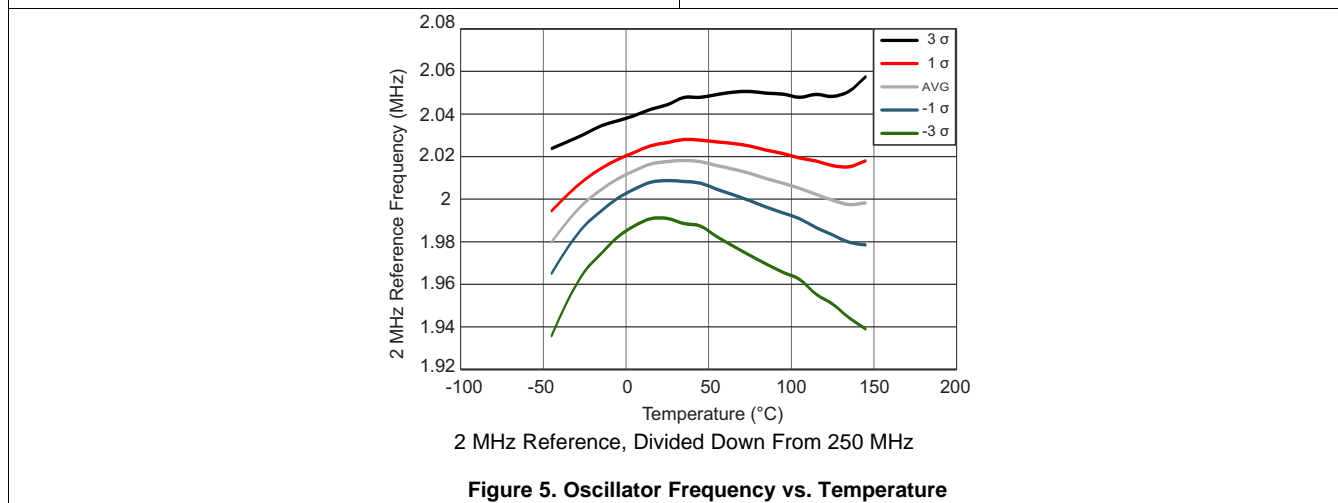

Figure 5. Oscillator Frequency vs. Temperature

## 7.9 Timing Diagrams

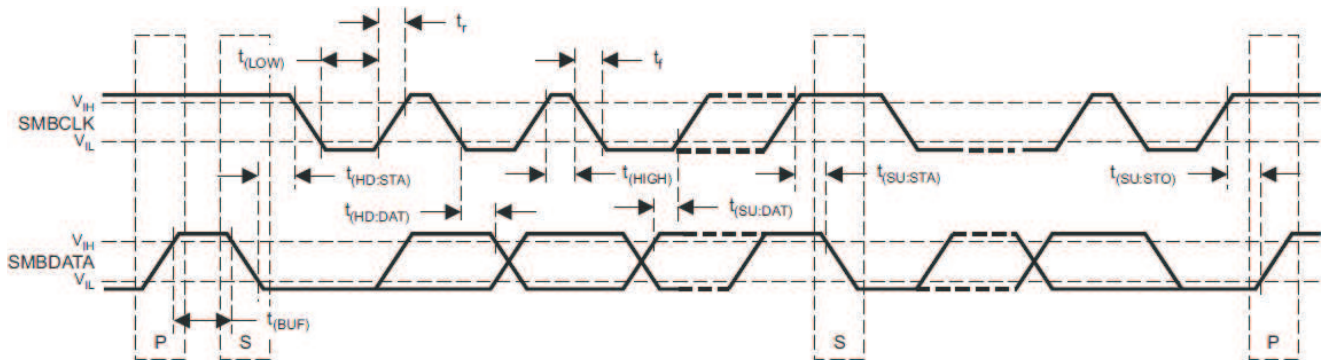

Figure 6. IC/SMBUS/PMBUS Timing Diagram<sup>2</sup>

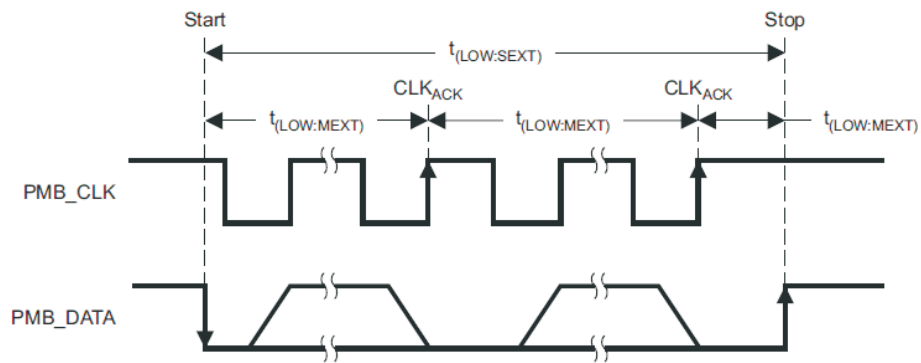

Figure 7. Bus Timing In Extended Mode

## 8 Parametric Measurement Information

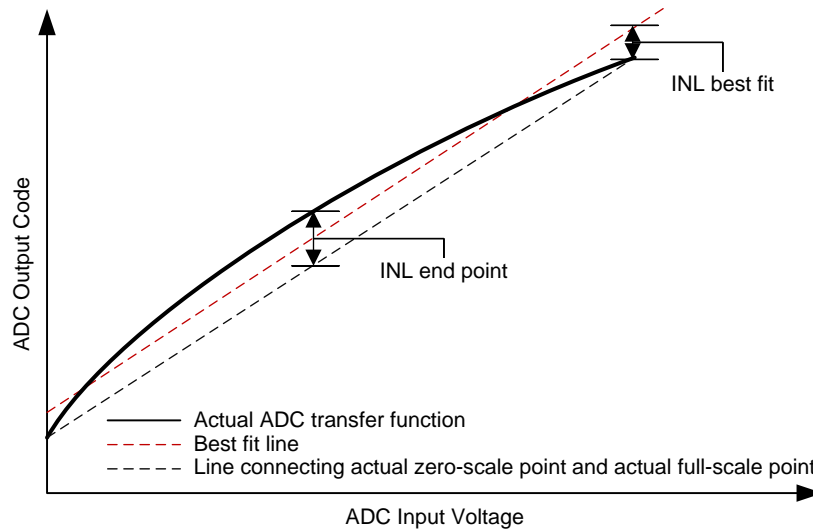

Figure 8. Best Fit INL and End Point INL

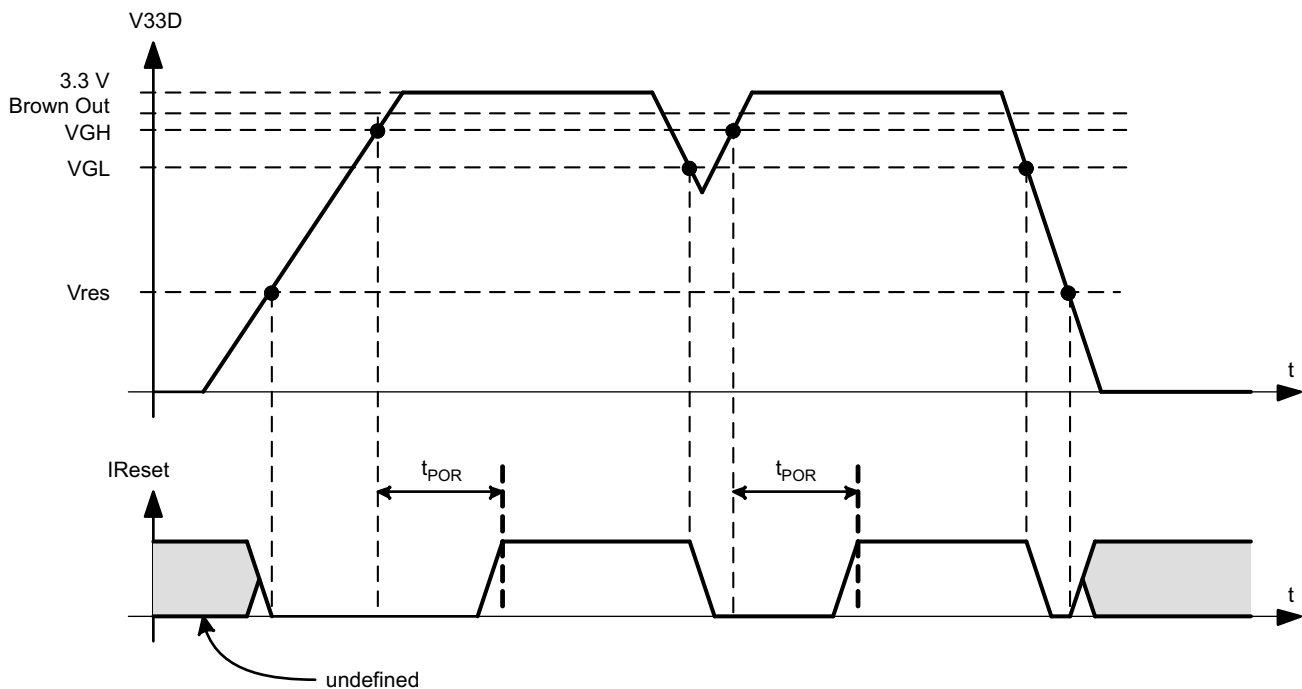
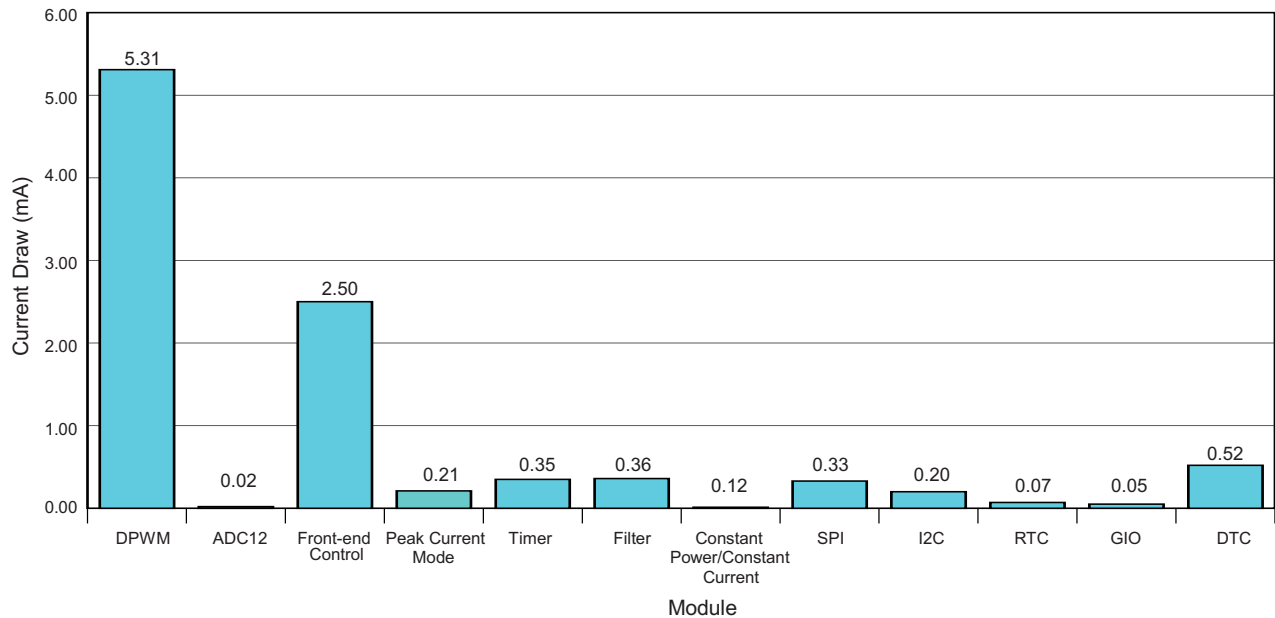

Figure 9. Power On Reset (POR) / Brown Out Reset (BOR)

- VGH – This is the V33A threshold where the internal power is declared good. The UCD3138xA comes out of reset when above this threshold.
- VGL – This is the V33A threshold where the internal power is declared bad. The device goes into reset when below this threshold.
- V<sub>res</sub> – This is the V33A threshold where the internal reset signal is no longer valid. Below this threshold the device is in an indeterminate state.
- I<sub>Reset</sub> – This is the internal reset signal. When low, the device is held in reset. This is equivalent to holding the reset pin on the IC low.

- t<sub>POR</sub> – The time delay from when V<sub>GH</sub> is exceeded to when the device comes out of reset.
- Brown Out – This is the V<sub>33A</sub> voltage threshold at which the device sets the brown out status bit. In addition an interrupt can be triggered if enabled.

### 8.1 Typical Clock Gating Power Savings



The CLKGATECTRL register provides control bits that can enable or disable the clock to several peripherals such as, PCM, CPCC, digital filters, front ends, DPWMs, UARTs, ADC-12 and more.

By default, all these controls are enabled. If a specific peripheral is not used the clock gate can be disabled in order to block the propagation of the clock signal to that peripheral and therefore reduce the overall current consumption of the device. The power savings chart displays the power savings per module. For example there are 4 DPWM modules, therefore, if all 4 are disabled a total of ~20 mA can be saved.

## 9 Detailed Description

### 9.1 Overview

The UCD3138xA family is a digital power supply controller from Texas Instruments offering superior levels of integration and performance in a single chip solution. The UCD3138128A, in comparison to Texas Instruments UCD3138A digital power controller offers 128 kB of program Flash memory. The flexible nature of the UCD3138xA family makes it suitable for a wide variety of power conversion applications.

In addition, multiple peripherals inside the device have been specifically optimized to enhance the performance of AC/DC and isolated DC/DC applications and reduce the solution component count in the IT and network infrastructure space. The UCD3138xA family is a fully programmable solution offering customers complete control of their application, along with ample ability to differentiate their solution. At the same time, TI is committed to simplifying our customer's development effort through offering best in class development tools, including application firmware, Code Composer Studio™ software development environment, and TI's Fusion Power Development GUI which enables customers to configure and monitor key system parameters.

#### 9.1.1 ARM Processor

The ARM7TDMI-S processor is a synthesizable member of the ARM family of general purpose 32-bit microprocessors. The ARM architecture is based on RISC (Reduced Instruction Set Computer) principles where two instruction sets are available. The 32-bit ARM instruction set and the 16-bit Thumb instruction set. The Thumb instructions allow for higher code density equivalent to a 16-bit microprocessor, with the performance of the 32-bit microprocessor.

The three-staged pipelined ARM processor has fetch, decode and execute stage architecture. Major blocks in the ARM processor include a 32-bit ALU, 32 x 8 multiplier, and a barrel shifter.

#### 9.1.2 Memory

The UCD3138xA (ARM7TDMI-S) is a Von-Neumann architecture, where a single bus provides access to all of the memory modules. All of the memory module addresses are sequentially aligned along the same address range. This applies to program flash, data flash, ROM and all other peripherals.

Within the UCD3138xA family architecture, there is a 1024x32-bit Boot ROM that contains the initial firmware startup routines for PMBus communication and non-volatile (FLASH) memory download. This boot ROM is executed after power-up-reset checks if there is a valid FLASH program written. If a valid program is present, the ROM code branches to the main FLASH-program execution. If there is no valid program, the device waits for a program download through the PMBus.

The UCD3138xA family also supports customization of the boot program by allowing an alternative boot routine to be executed from program FLASH. This feature enables assignment of a unique address to each device; therefore, enabling firmware reprogramming even when several devices are connected on the same communication bus.

There are three separate flash memory areas present inside the device. There are 4-32 kB program flash blocks and 1-2 kB data flash area. The 32 kB program areas are organized as 8 k x 32 bit memory blocks and are intended to be for the firmware programs. The blocks are configured with page erase capability for erasing blocks as small as 1 kB per page, or with a mass erase for erasing the entire 32 kB array. The flash endurance is specified at 1000 erase/write cycles and the data retention is good for 100 years. The 2 kB data flash array is organized as a 512 x 32 bit memory (32 byte page size). The data flash is intended for firmware data value storage and data logging. Thus, the Data flash is specified as a high endurance memory of 20 k cycles with embedded error correction code (ECC).

## Overview (continued)

For run time data storage and scratchpad memory, a 8 kB RAM is available. The RAM is organized as a 2 k x 32 bit array.

The availability of 128 kB of program Flash memory in 4-32 kB banks, respectively enables the designers to implement multiple images of firmware (e.g. one main image + one back-up image) in the device and the flexibility to execute from either of the banks using appropriate algorithms. It also creates the unique opportunity for the processor to load a new program and subsequently execute that program without interrupting power delivery. This feature allows the end user to add new features to the power supply while eliminating any down-time required to load the new program.

On the UCD3138128A, the boot ROM supports a dual image configuration where each image contains 64 kB. If the first 64kB has an invalid program, the boot ROM will check for a valid program in the second 64kB and jump there. The boot ROM also supports a configuration with a single program occupying the entire 128 kB.

For the UCD3138128A, on the fly updates are supported through boot ROM. Detailed procedures can be found in [SLUUB54](#)

## 9.2 Functional Block Diagram

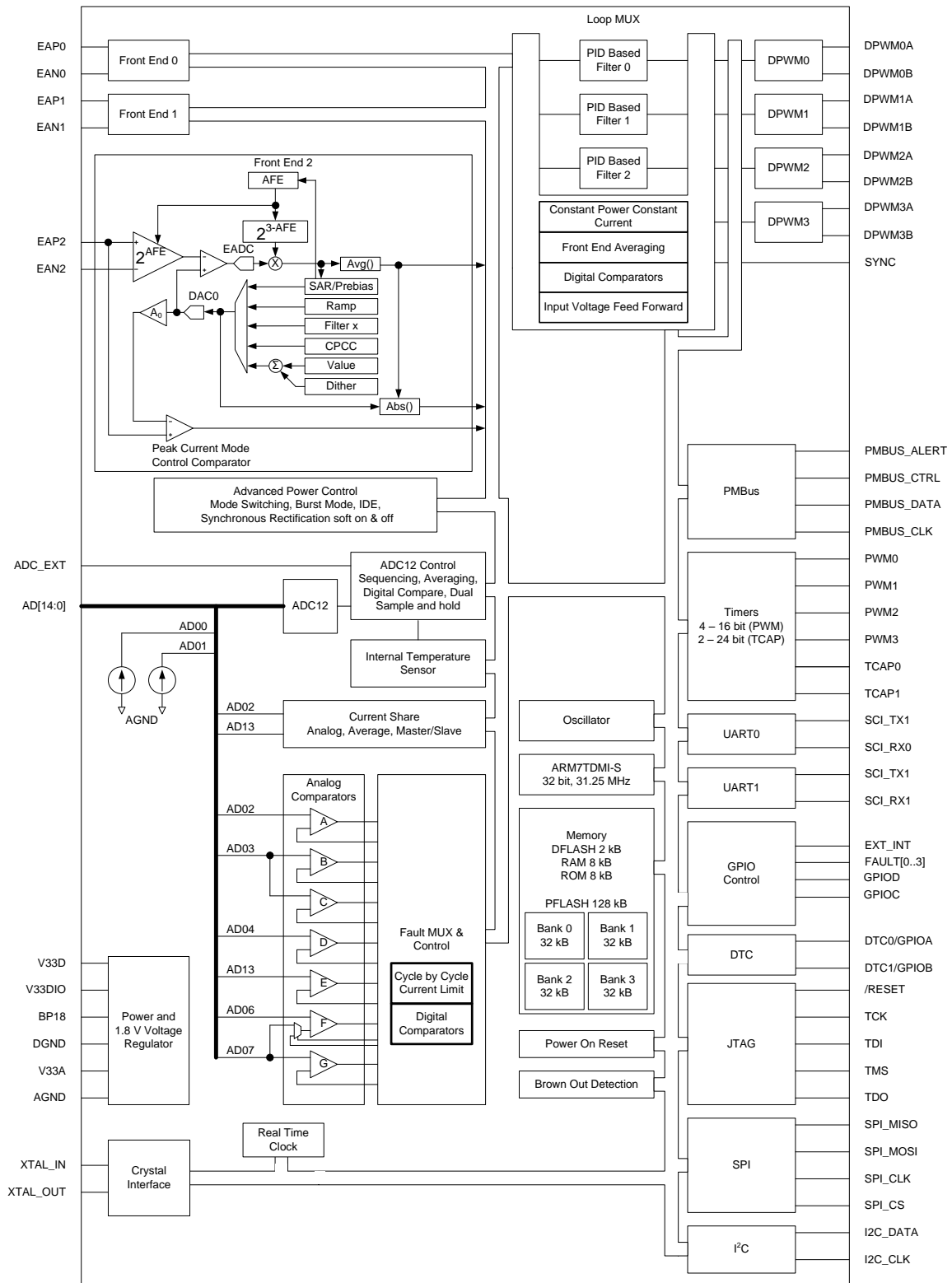

Copyright © 2016, Texas Instruments Incorporated

## 9.3 Feature Description

### 9.3.1 System Module

The System Module contains the interface logic and configuration registers to control and configure all the memory, peripherals and interrupt mechanisms. The blocks inside the system module are the address decoder, memory management controller, system management unit, central interrupt unit, and clock control unit.

#### 9.3.1.1 Address Decoder (DEC)

The Address Decoder generates the memory selects for the FLASH, ROM and RAM arrays. The memory map addresses are selectable through configurable register settings. These memory selects can be configured from 1 kB to 16 MB. Power on reset uses the default addresses in the memory map for ROM execution, which is then configured by the ROM code to the application setup. During access to the DEC registers, a wait state is asserted to the CPU. DEC registers are only writable in the ARM privilege mode for user mode protection.

#### 9.3.1.2 Memory Management Controller (MMC)

The MMC manages the interface to the peripherals by controlling the interface bus for extending the read and write accesses to each peripheral. The unit generates eight peripheral select lines with 1 kB of address space decoding.

#### 9.3.1.3 System Management (SYS)

The SYS unit contains the software access protection by configuring user privilege levels to memory or peripherals modules. It contains the ability to generate fault or reset conditions on decoding of illegal address or access conditions. A clock control setup for the processor clock (MCLK) speed, is also available.

#### 9.3.1.4 Central Interrupt Module (CIM)

The CIM accepts 32 interrupt requests for meeting firmware timing requirements. The ARM processor supports two interrupt levels: FIQ and IRQ. FIQ is the highest priority interrupt. The CIM provides hardware expansion of interrupts by use of FIQ/IRQ vector registers for providing the offset index in a vector table. This numerical index value indicates the highest precedence channel with a pending interrupt and is used to locate the interrupt vector address from the interrupt vector table. Interrupt channel 0 has the lowest precedence and interrupt channel 31 has the highest precedence. To remove the interrupt request, the firmware should clear the request as the first action in the interrupt service routine. The request channels are maskable, allowing individual channels to be selectively disabled or enabled.

**Feature Description (continued)**
**Table 3. Interrupt Priority Table**

NAME	MODULE COMPONENT OR REGISTER	DESCRIPTION	PRIORITY
BRN_OUT_INT	Brownout	Brownout interrupt	0 (Lowest)
EXT_INT	External Interrupts	Interrupt on external input pin	1
WDRST_INT	Watchdog Control	Interrupt from watchdog exceeded (reset)	2
WDWAKE_INT	Watchdog Control	Wake-up interrupt when watchdog equals half of set watch time	3
SCI_ERR_INT	UART or SCI Control	UART or SCI error Interrupt. Frame, parity or overrun	4
SCI_RX_0_INT	UART or SCI Control	UART0 RX buffer has a byte	5
SCI_TX_0_INT	UART or SCI Control	UART0 TX buffer empty	6
SCI_RX_1_INT	UART or SCI Control	UART1 RX buffer has a byte	7
SCI_TX_1_INT	UART or SCI Control	UART1 TX buffer empty	8
PMBUS_INT	PMBus	PMBus related interrupt	9
DIG_COMP_SPI_I2C_INT	12-bit ADC Control, SPI, I <sup>2</sup> C	Digital comparator, SPI and I <sup>2</sup> C interrupt	10
FE0_INT	Front End 0	"Prebias complete", "Ramp Delay Complete", "Ramp Complete", "Load Step Detected", "Over-Voltage Detected", "EADC saturated"	11
FE1_INT	Front End 1	"Prebias complete", "Ramp Delay Complete", "Ramp Complete", "Load Step Detected", "Over-Voltage Detected", "EADC saturated"	12
FE2_INT	Front End 2	"Prebias complete", "Ramp Delay Complete", "Ramp Complete", "Load Step Detected", "Over-Voltage Detected", "EADC saturated"	13
PWM3_INT	16-bit Timer PWM 3	16-bit Timer PWM3 counter overflow or compare interrupt	14
PWM2_INT	16-bit Timer PWM 2	16-bit Timer PWM2 counter Overflow or compare interrupt	15
PWM1_INT	16-bit Timer PWM 1	16-bit Timer PWM1 counter overflow or compare interrupt	16
PWM0_INT	16-bit timer PWM 0	16-bit Timer PWM0 counter overflow or compare interrupt	17
OVF24_INT	24-bit Timer Control	24-bit Timer counter overflow interrupt	18
CAPTURE1_DTC_INT	24 bit Timer Control or DTC	24 bit Timer capture 1 interrupt or DTC fault interrupt	19
COMP_1_INT	24-bit Timer Control	24-bit Timer compare 1 interrupt	20
CAPTURE_0_INT	24-bit Timer Control	24-bit Timer capture 0 interrupt	21
COMP_0_INT	24-bit Timer Control	24-bit Timer compare 0 interrupt	22
CPCC_RTC_INT	Constant Power Constant Current or Real Time Clock Output	Mode switched in CPCC module Flag needs to be read for details. RTC timer output generates an interrupt.	23
ADC_CONV_INT	12-bit ADC Control	ADC end of conversion interrupt	24
FAULT_INT	Fault Mux Interrupt	Analog comparator interrupts, Over-Voltage detection, Under-Voltage detection, LLM load step detection	25
DPWM3	DPWM3	Same as DPWM1	26
DPWM2	DPWM2	Same as DPWM1	27
DPWM1	DPWM1	1) Every (1-256) switching cycles 2) Fault Detection 3) Mode switching	28
DPWM0	DPWM0	Same as DPWM1	29
EXT_FAULT_INT	External Faults	Fault pin interrupt	30
SYS_SSI_INT	System Software	System software interrupt	31 (highest)

## 9.3.2 Peripherals

### 9.3.2.1 Digital Power Peripherals (DPPs)

At the core of the UCD3138xA controller are three DPPs. Each DPP can be configured to drive from one to eight DPWM outputs. Each DPP consists of:

- Differential input error ADC (EADC) with sophisticated controls
- Hardware accelerated digital 2-pole/2-zero PID based compensator
- Digital PWM module with support for a variety of topologies

These can be connected in many different combinations, with multiple filters and DPWMs. They are capable of supporting functions like input voltage feed forward, current mode control, and constant current/constant power, and so on. The simplest configuration is shown in [Figure 10](#).

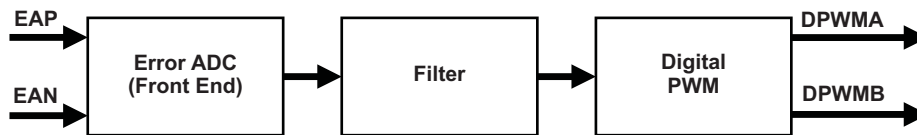

**Figure 10. Multiple Filters and DPWMs**

#### 9.3.2.1.1 Front End

[Figure 11](#) shows the block diagram of the front end module. It consists of a differential amplifier, an adjustable gain error amplifier, a high speed flash analog to digital converter (EADC), digital averaging filters and a precision high resolution set point DAC reference. The programmable gain amplifier in concert with the EADC and the adjustable digital gain on the EADC output work together to provide 9 bits of range with 6 bits of resolution on the EADC output. The output of the Front End module is a 9-bit sign extended result with a gain of 1 LSB / mV. Depending on the value of AFE selected, the resolution of this output could be either 1, 2, 4 or 8 LSBs. In addition each EADC has the ability to automatically select the AFE value such that the minimum resolution is maintained that still allows the voltage to fit within the range of the measurement. The EADC control logic receives the sample request from the DPWM module for initiating an EADC conversion. EADC control circuitry captures the EADC-9-bit-code and strobes the digital compensator for processing of the representative error. The set point DAC has 10 bits with an additional 4 bits of dithering resulting in an effective resolution of 14 bits. This DAC can be driven from a variety of sources to facilitate things like soft start, nested loops, and so on. Some additional features include the ability to change the polarity of the error measurement and an absolute value mode which automatically adds the DAC value to the error.

It is possible to operate the controller in a peak current mode control configuration; an EADC is recommended for implementing peak current mode control. In this mode, topologies like a phase shifted full bridge converter can be controlled to maintain transformer flux balance. The internal DAC can be ramped at a synchronously controlled slew rate to achieve a programmable slope compensation. This eliminates the sub-harmonic oscillation as well as improves input voltage feed-forward performance. A0 is a unity gain buffer used to isolate the peak current mode comparator. The offset of this buffer is specified in [Electrical Characteristics](#).

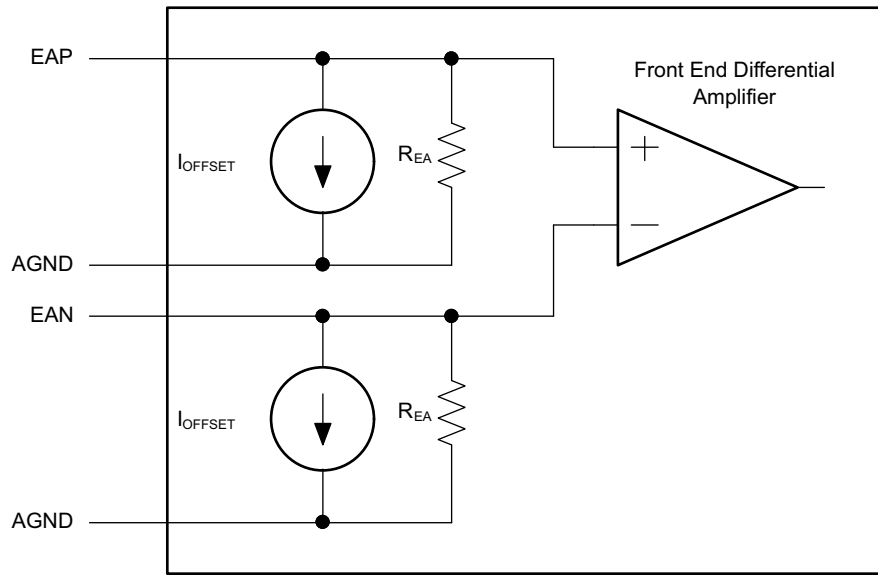

Figure 11. Input Stage of EADC Module

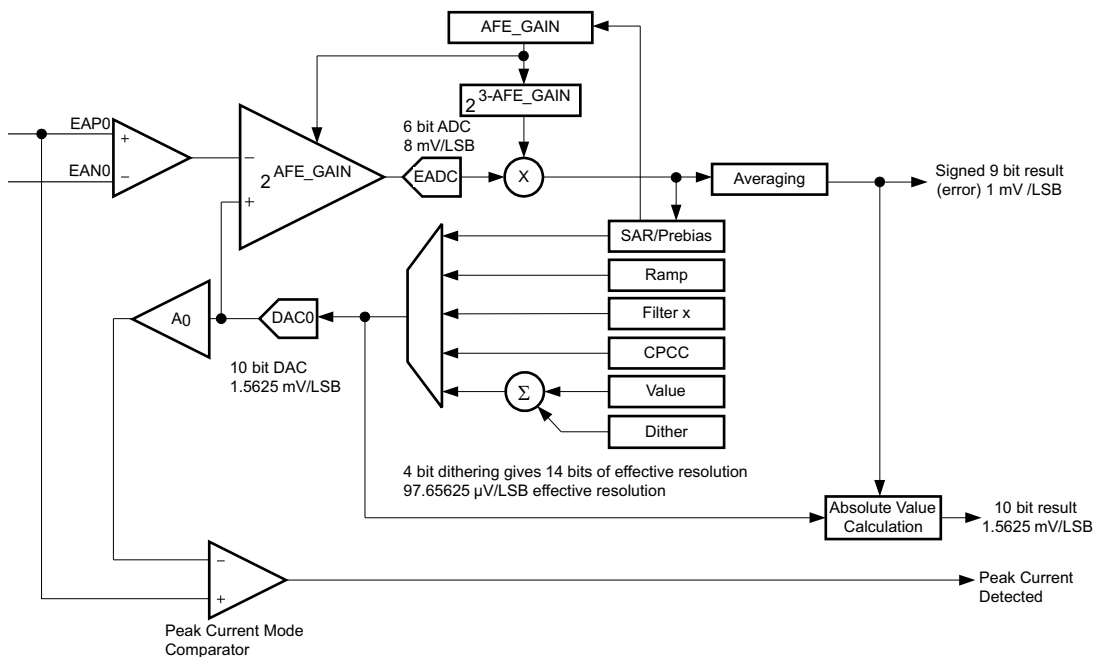

Figure 12. Front End Module  
(Front End 2 Recommended for Peak Current Mode Control)

### 9.3.2.1.2 DPWM Module

The DPWM module represents one complete DPWM channel with 2 independent outputs, A and B. Multiple DPWM modules within the UCD3138xA system can be configured to support all key power topologies. DPWM modules can be used as independent DPWM outputs, each controlling one power supply output voltage rail. It can also be used as a synchronized DPWM—with user selectable phase shift between the DPWM channels to control power supply outputs with multiphase or interleaved DPWM configurations.

The output of the filter feeds the high resolution DPWM module. The DPWM module produces the pulse width modulated outputs for the power stage switches. The compensator calculates the duty ratio as a 24-bit number in Q23 fixed point format (23 bit integer with 1 sign bit). This represents a value within the range 0.0 to 1.0. This duty ratio value is used to generate the corresponding DPWM output ON time. The resolution of the DPWM ON time is 250 psec.

Each DPWM module can be synchronized to another module or to an external sync signal. An input SYNC signal causes a DPWM ramp timer to reset. The SYNC signal outputs—from each of the four DPWM modules—occur when the ramp timer crosses a programmed threshold. In this way the phase of the DPWM outputs for multiple power stages can be tightly controlled.

The DPWM logic is probably the most complex of the Digital Peripherals. It receives the output of the compensator and converts it into the correct DPWM output for several power supply topologies. It provides for programmable dead times and cycle adjustments for current balancing between phases. It controls the triggering of the EADC. It can synchronize to other DPWMs or to external sources. It can provide synchronization information to other DPWMs or to external recipients. In addition, it interfaces to several fault handling circuits. Some of the control for these fault handling circuits is in the DPWM registers. Fault handling is covered in the Fault Mux section.

Each DPWM module supports the following features:

- Dedicated 14 bit time-base with period and frequency control
- Shadow period register for end of period updates.
- Quad-event control registers (A and B, rising and falling) (Events 1 to 4)
  - Used for on/off DPWM duty ratio updates.
- Phase control relative to other DPWM modules
- Sample trigger placement for output voltage sensing at any point during the DPWM cycle.
- Support for two independent edge placement DPWM outputs (same frequency or period setting)
- Dead-time between DPWM A and B outputs
- High Resolution capabilities – 250 ps
- Pulse cycle adjustment of up to  $\pm 8.192 \mu\text{s}$  ( $32768 \times 250 \text{ ps}$ )
- Active high/ active low output polarity selection
- Provides events to trigger both CPU interrupts and start of ADC12 conversions.

The DPWM is a complex logic system which is highly configurable to support different power supply topologies. For details about the DPWM operation modes, refer to [Device Functional Modes](#).

### 9.3.2.1.3 DPWM Events

Each DPWM can control the following timing events:

1. *Sample Trigger Count*—This register defines where the error voltage is sampled by the EADC in relationship to the DPWM period. The programmed value set in the register should be one fourth of the value calculated based on the DPWM clock. The clock controlling the circuitry runs at one fourth of the DPWM clock (PCLK = 250 MHz max). When this sample trigger count is equal to the DPWM Counter, it initiates a front end calculation by triggering the EADC, resulting in a CLA calculation, and a DPWM update. Oversampling can be set for 2, 4, or 8 times the sampling rate.
2. *Phase Trigger Count* – count offset for slaving another DPWM (Multi-Phase/Interleaved operation).
3. *Period* – low resolution switching period count. (count of PCLK cycles)
4. *Event 1* – count offset for rising DPWM A event. (PCLK cycles)
5. *Event 2* – DPWM count for falling DPWM A event that sets the duty ratio. Last 4 bits of the register are for high resolution control. Upper 14 bits are the number of PCLK cycle counts.
6. *Event 3* – DPWM count for rising DPWM B event. Last 4 bits of the register are for high resolution control. Upper 14 bits are the number of PCLK cycle counts.
7. *Event 4* – DPWM count for falling DPWM B event. Last 4 bits of the register are for high resolution control. Upper 14 bits are the number of PCLK cycle counts.
8. *Cycle Adjust* – Constant offset for Event 2 and Event 4 adjustments.

Basic comparisons between the programmed registers and the DPWM counter can create the desired edge placements in the DPWM. High resolution edge capability is available on Events 2, 3, and 4.

Figure 13 is for multi-mode, open loop. Open loop means that the DPWM is controlled entirely by its own registers, not by the filter output. In other words, the power supply control loop is not closed.

The Sample Trigger signals are used to trigger the front end to sample input signals. The Blanking signals are used to blank fault measurements during noisy events, such as FET turn on and turn off.

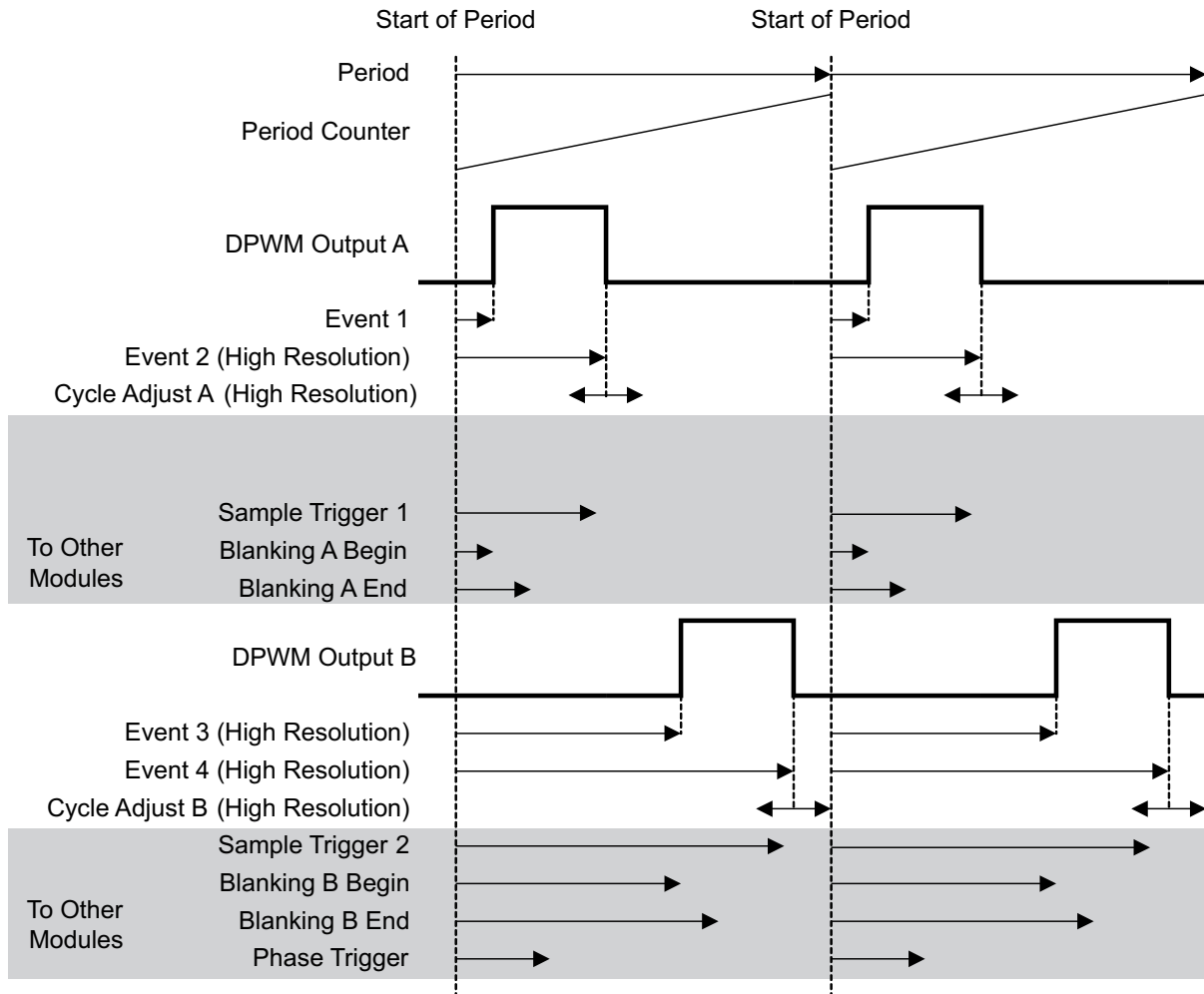

Events which change with DPWM mode:

- DPWM A Rising Edge = Event 1
- DPWM A Falling Edge = Event 2 + Cycle Adjust A
- DPWM B Rising Edge = Event 3
- DPWM B Falling Edge = Event 4 + Cycle Adjust B
- Phase Trigger = Phase Trigger Register value or Filter Duty

Events always set by their registers, regardless of mode:

- Sample Trigger 1, Sample Trigger 2, Blanking A Begin, Blanking A End, Blanking B Begin, Blanking B End
- Begin, Blanking B End

**Figure 13. Multi Mode Open Loop**

### 9.3.2.1.4 High Resolution DPWM

Unlike conventional PWM controllers where the frequency of the clock dictates the maximum resolution of PWM edges, the UCD3138xA DPWM can generate waveforms with resolutions as small as 250 ps. This is 16x the resolution of the clock driving the DPWM module.

This is achieved by providing the DPWM mechanism with 16 phase shifted clock signals of 250 MHz. The high resolution section of DPWM can be enabled or disabled, and the resolution can be defined in several steps between 4 ns to 250 ps. This is done by setting the values of PWM\_HR\_MULTI\_OUT\_EN and HIRES\_SCALE inside the DPWM Control register 1. See the Power Peripherals programmer's manual for details.

### 9.3.2.1.5 Oversampling

The DPWM module has the capability to trigger an oversampling event by initiating the EADC to sample the error voltage. The default 00 configuration has the DPWM trigger the EADC once based on the sample trigger register value. The over sampling register has the ability to trigger the sampling 2, 4 or 8 times per PWM period. Thus the time the over sample happens is at the divide by 2, 4, or 8 time set in the sampling register. The 01 setting triggers 2X oversampling, the 10 setting triggers 4X over sampling, and the 11 triggers oversampling at 8X.

### 9.3.2.1.6 DPWM Interrupt Generation

The DPWM has the capability to generate a CPU interrupt based on the PWM frequency programmed in the period register. The interrupt can be scaled by a divider ratio of up to 255 for developing a slower interrupt service execution loop. This interrupt can be fed to the ADC circuitry for providing an ADC12 trigger for sequence synchronization. [Table 4](#) outlines the divide ratios that can be programmed.

### 9.3.2.1.7 DPWM Interrupt Scaling/Range

**Table 4. DPWM Interrupt Divide Ratio**

Interrupt Divide Setting	Interrupt Divide Count	Interrupt Divide Count (hex)	Switching Period Frames (Assume 1-MHz Loop)	Number of 32-MHz Processor Cycles
1	0	00	1	32
2	1	01	2	64
3	3	03	4	128
4	7	07	8	256
5	15	0F	16	512
6	31	1F	32	1024
7	47	2F	48	1536
8	63	3F	64	2048
9	79	4F	80	2560
10	95	5F	96	3072
11	127	7F	128	4096
12	159	9F	160	5120
13	191	BF	192	6144
14	223	DF	224	7168
15	255	FF	256	8192

### 9.3.2.1.8 Synchronous Rectifier Dead Time Optimization Peripheral

The UCD3138xA has an advanced dead time control interface where it can accept UCD7138 output signals and optimize SR gate driver signals accordingly. The UCD7138 low-side MOSFET driver is a high-performance driver for secondary-side synchronous rectification (SR) with body diode conduction sensing. The device is suitable for high power high efficiency isolated converter applications where dead-time optimization is desired. The UCD7138 gate driver is a companion device to UCD3138xA highly integrated digital controller for isolated power.

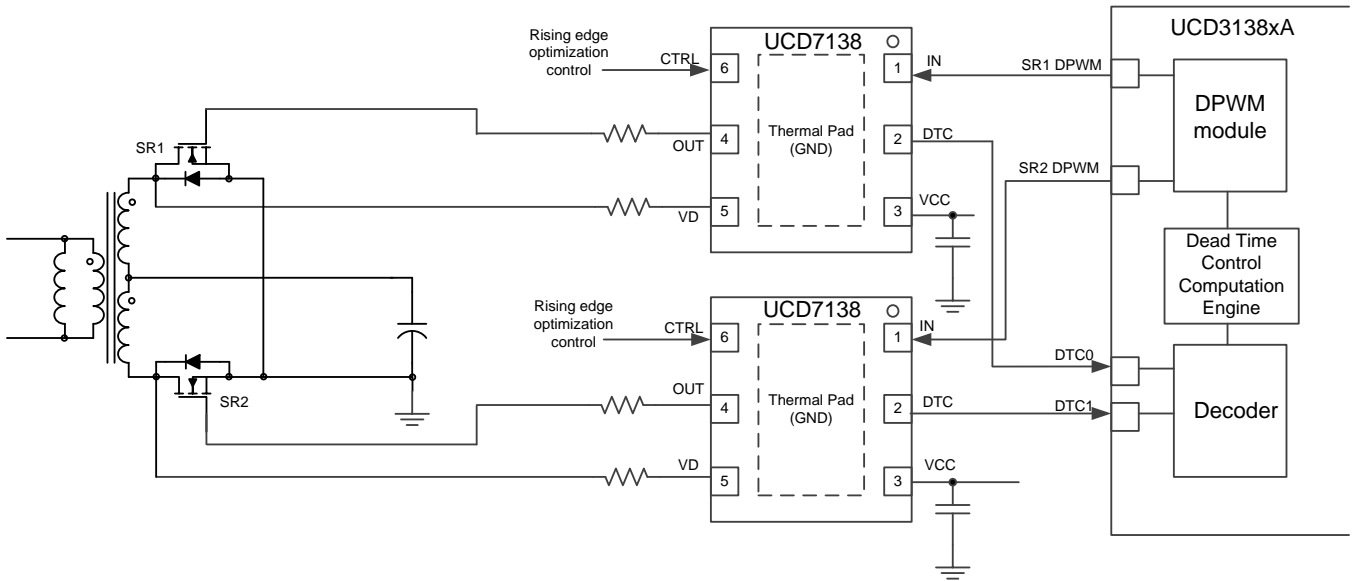

Copyright © 2016, Texas Instruments Incorporated

**Figure 14. Synchronous Rectifier Peripheral use with Synchronous Rectifier Driver**

DTC0 and DTC1 are received body diode conduction inputs from UCD7138. SR0\_DPWM and SR1\_DPWM are the DPWM waveforms for the SRs. The red and green edges are moving edges controlled by both the filter output and the DTC interface. In each cycle, right after the falling edge of the SR DPWM waveform, a body diode conduction time detection window is generated. The detection window is defined by both DETECT\_BLANK and DETECT\_LEN registers. During this detection window, a 4-ns timer capture counts how long the body diode conducts. Then the DPWM turn off edge of the next cycle is adjusted accordingly.

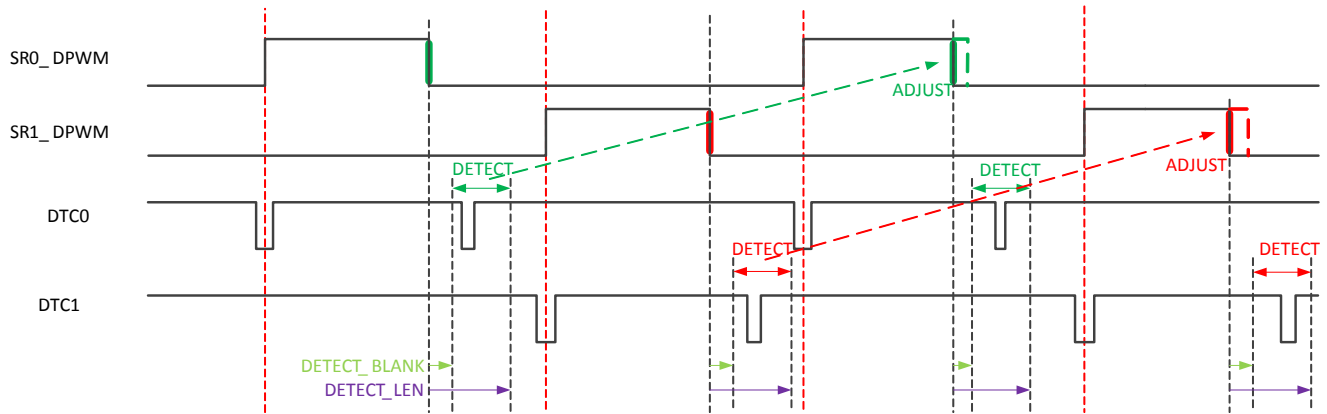

**Figure 15. Timing Diagram of the DTC Interface**

Figure 16 shows how the turn off edge is adjusted based on the DTC measurement of the previous cycle. The A\_ADJ and B\_ADJ registers in DTCMONITOR are signed accumulators; default value is 0.

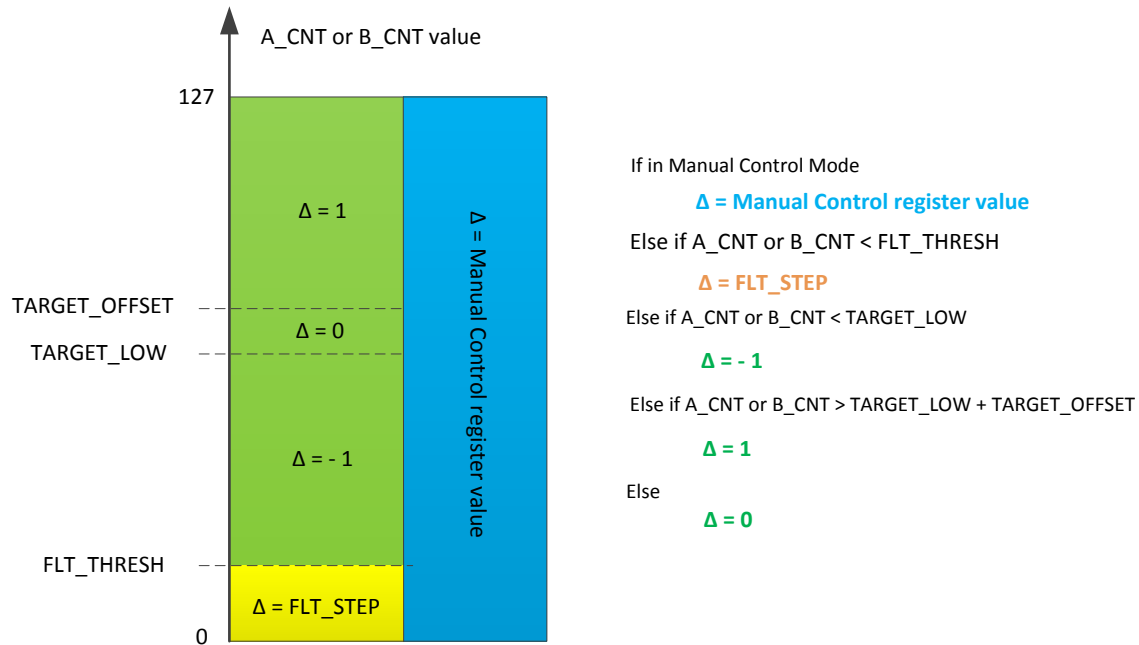

Figure 16. DTC Interface Principle

Based on the DTC measured, in the next cycle:

- $A\_ADJ = A\_ADJ + A\_Δ$
- $B\_ADJ = B\_ADJ + B\_Δ$

In each cycle, the A\_ADJ and B\_ADJ accumulator values are dynamically adjust the dead time. The  $\Delta$  value changes after the measured body diode conduction time. A\_ADJ and B\_ADJ have been measured and compared to the threshold values in automatic control mode. A\_ADJ and B\_ADJ can be controlled by firmware while in manual control mode.

Other figures of this peripheral include negative current fault protection, consecutive fault counter, DTC input multiplexor, etc. For details, refer to the programmer's manual.

### 9.3.3 Automatic Mode Switching

Automatic Mode switching enables the DPWM module to switch between modes automatically, with no firmware intervention. This is useful to increase efficiency and power range. The following paragraphs describe phase-shifted full bridge and LLC examples.

#### 9.3.3.1 Phase Shifted Full Bridge Example

In phase shifted full bridge topologies, efficiency can be increased by using pulse width modulation, rather than phase shift, at light load. This is shown below:

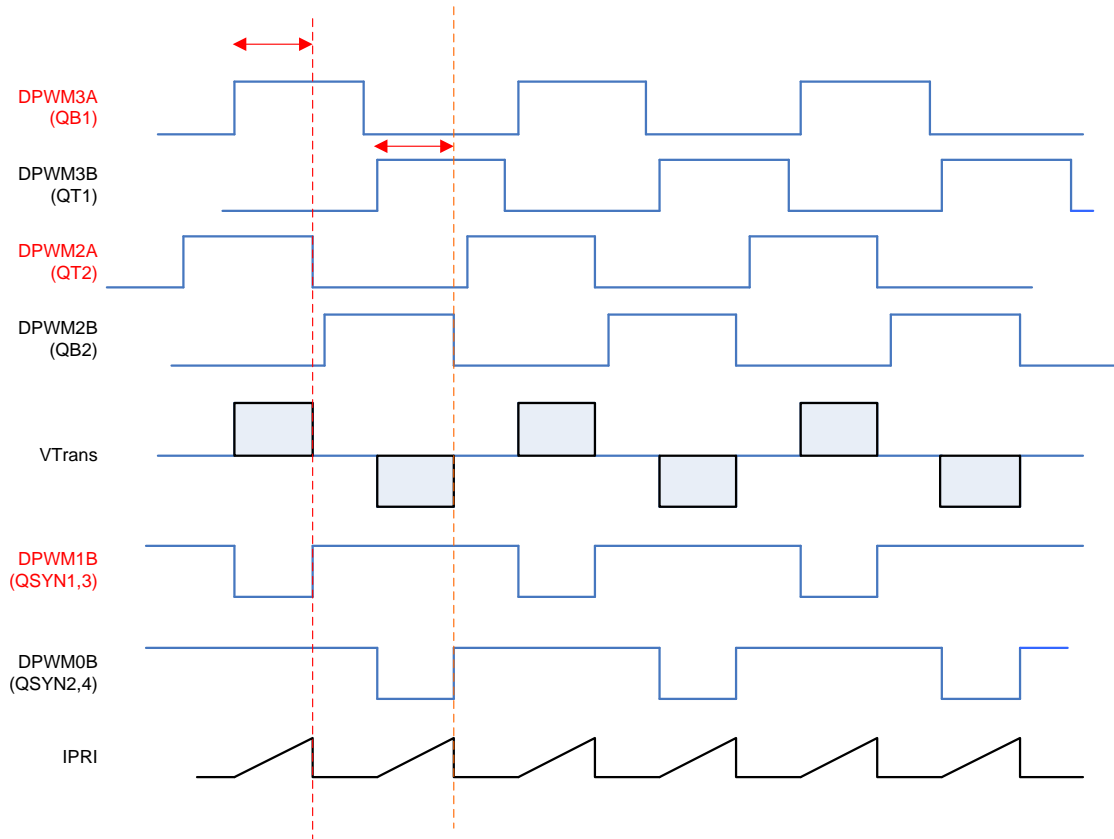

**Figure 17. Phase-Shifted Full Bridge Waveforms**

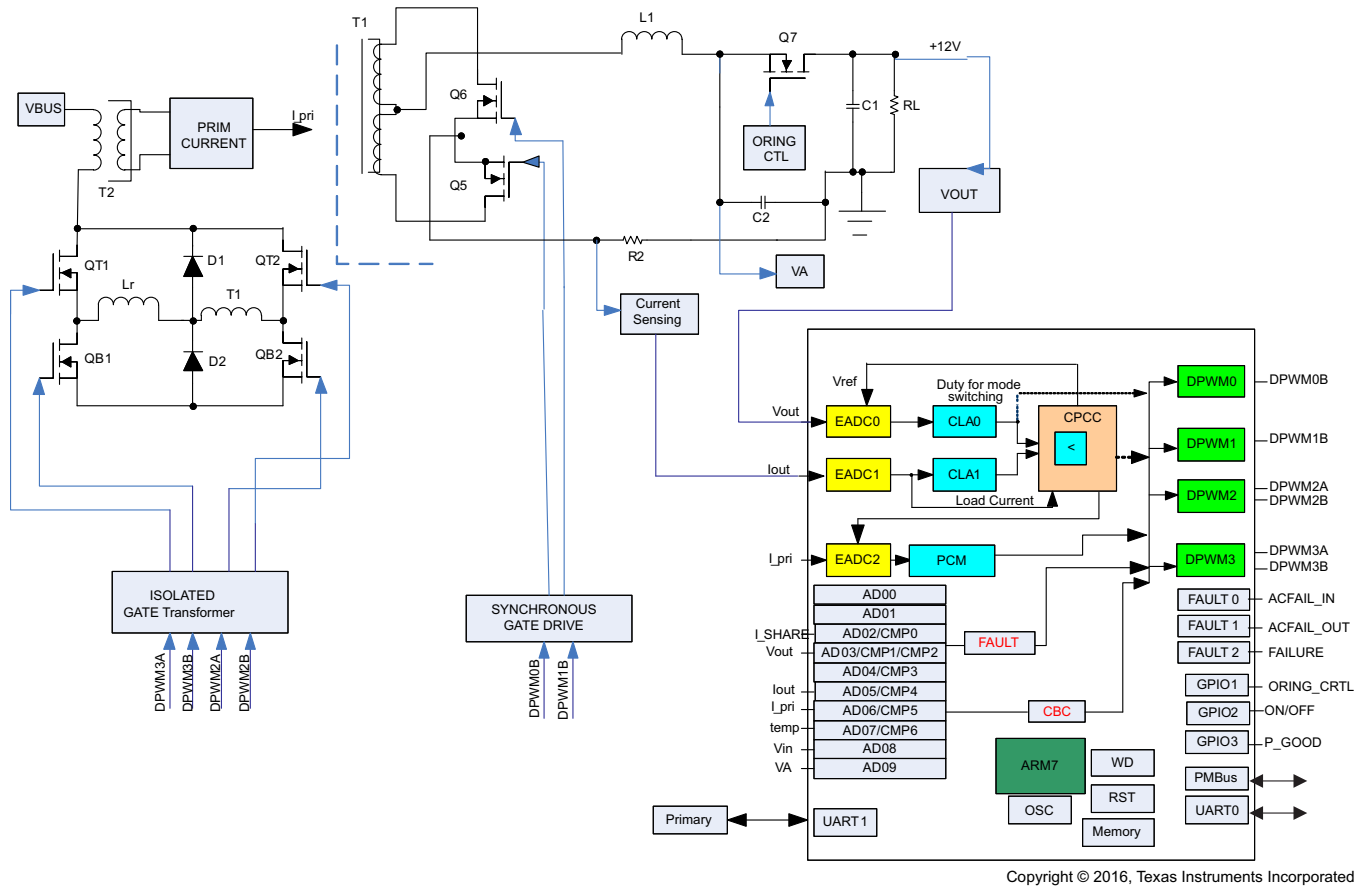

Figure 18. Secondary-Referenced Phase-Shifted Full Bridge Control With Synchronous Rectification

### 9.3.3.2 LLC Example

In LLC, three modes are used. At the highest frequency, a pulse width modulated mode (Multi Mode) is used. As the frequency decreases, resonant mode is used. As the frequency gets still lower, the synchronous MOSFET drive changes so that the on-time is fixed and does not increase. In addition, the LLC control supports cycle-by-cycle current limiting. This protection function operates by a comparator monitoring the maximum current during the DPWMA conduction time. Any time this current exceeds the programmable comparator reference the pulse is immediately terminated. Due to classic instability issues associated with half-bridge topologies it is also possible to force DPWMB to match the truncated pulse width of DPWMA. Here are the waveforms for the LLC:

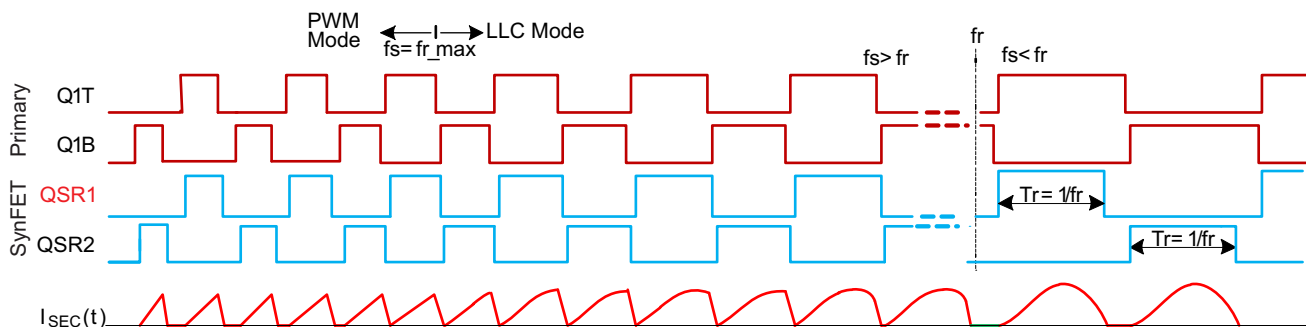
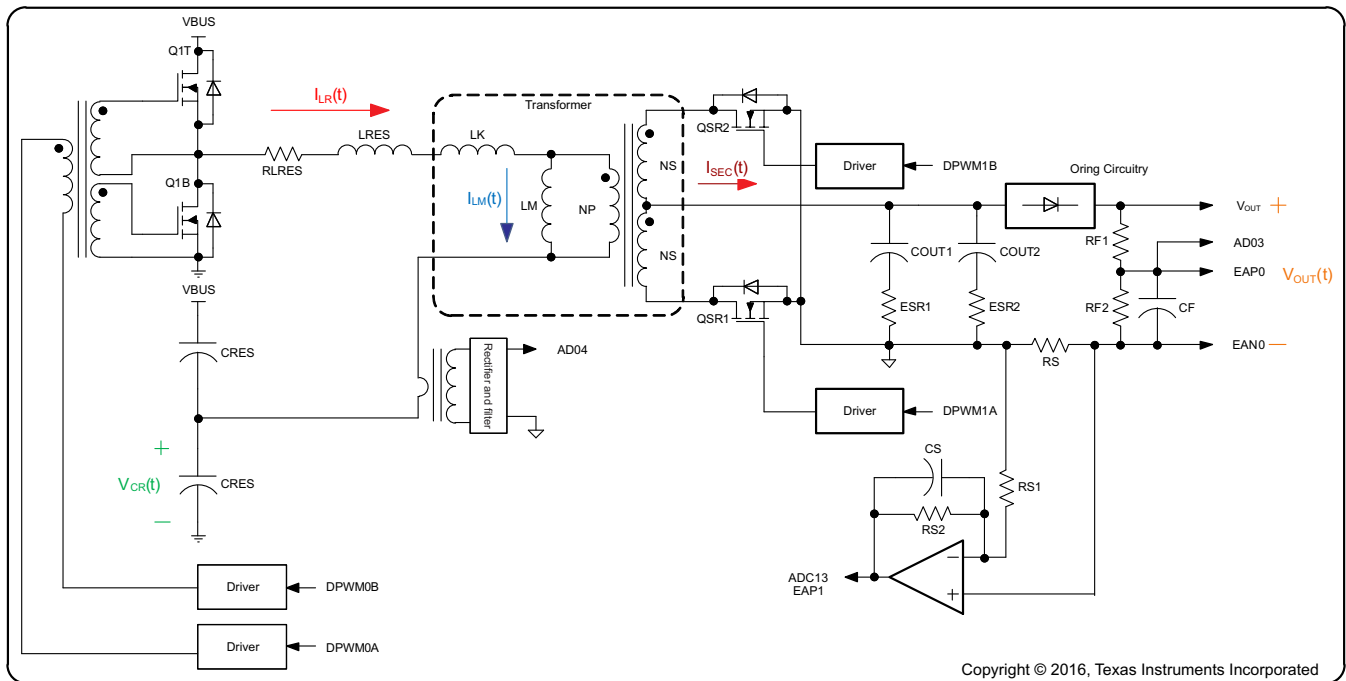

Figure 19. LLC Waveforms



Copyright © 2016, Texas Instruments Incorporated

Figure 20. Secondary-Referenced Half-Bridge Resonant LLC Control With Synchronous Rectification

### 9.3.3.3 Mechanism For Automatic Mode Switching

The UCD3138xA allows the customer to enable up to two distinct levels of automatic mode switching. These different modes are used to enhance light load operation, short circuit operation and soft start. Many of the configuration parameters for the DPWM are in DPWM Control Register 1. For automatic mode switching, some of these parameters are duplicated in the Auto Config Mid and Auto Config High registers.

If automatic mode switching is enabled, the filter duty signal is used to select which of these three registers is used. There are 4 registers which are used to select the points at which the mode switching takes place. They are used as shown below.

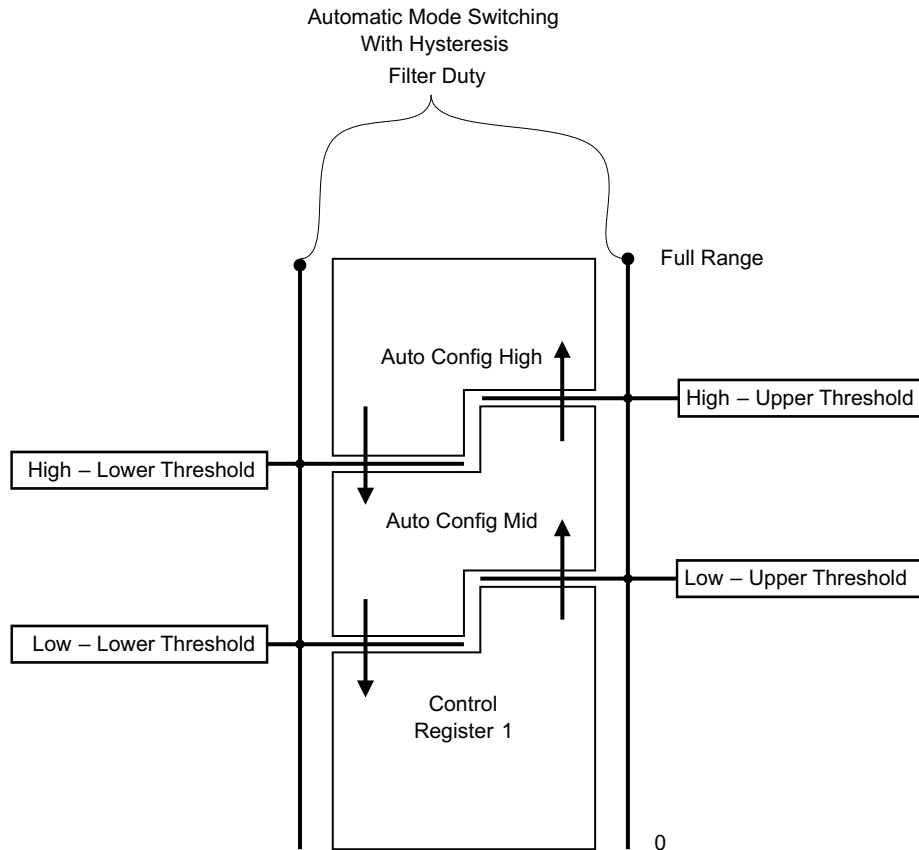

Figure 21. Automatic Mode Switching

As shown, the registers are used in pairs for hysteresis. The transition from Control Register 1 to Auto Config Mid only takes place when the Filter Duty goes above the Low Upper threshold. It does not go back to Auto Config Mid until the Low Lower Threshold is passed. This prevents oscillation between modes if the filter duty is close to a mode switching point.

### 9.3.4 DPWMC, Edge Generation, Intramux

The UCD3138xA has hardware for generating complex waveforms beyond the simple DPWMA and DPWMB waveforms already discussed – DPWMC, the Edge Generation Module, and the IntraMux.

DPWMC is a signal inside the DPWM logic. It goes high at the Blanking A begin time, and low at the Blanking A end time.

The Edge Gen module takes DPWMA and DPWMB from its own DPWM module, and the next one, and uses them to generate edges for two outputs. For DPWM3, the DPWM0 is considered to be the next DPWM. Each edge (rising and falling for DPWMA and DPWMB) has 8 options which can cause it.

The options are:

- 0 = DPWM(n) A Rising edge

- 1 = DPWM(n) A Falling edge
- 2 = DPWM(n) B Rising edge
- 3 = DPWM(n) B Falling edge
- 4 = DPWM(n+1) A Rising edge
- 5 = DPWM(n+1) A Falling edge
- 6 = DPWM(n+1) B Rising edge
- 7 = DPWM(n+1) B Falling edge

Where “n” is the numerical index of the DPWM module of interest. For example n=1 refers to DPWM1.

The Edge Gen is controlled by the DPWMEDGEGEN register. It also has an enable/disable bit.

The IntraMux is controlled by the Auto Config registers. Intra Mux is short for intra multiplexer. The IntraMux takes signals from multiple DPWMs and from the Edge Gen and combines them logically to generate DPWMA and DPWMB signals. This is useful for topologies like phase-shifted full bridge, especially when they are controlled with automatic mode switching. Of course, it can all be disabled, and DPWMA and DPWMB will be driven as described in the sections above. If the Intra Mux is enabled, high resolution must be disabled, and DPWM edge resolution goes down to 4 ns.

Here is a drawing of the Edge Gen/Intra Mux:

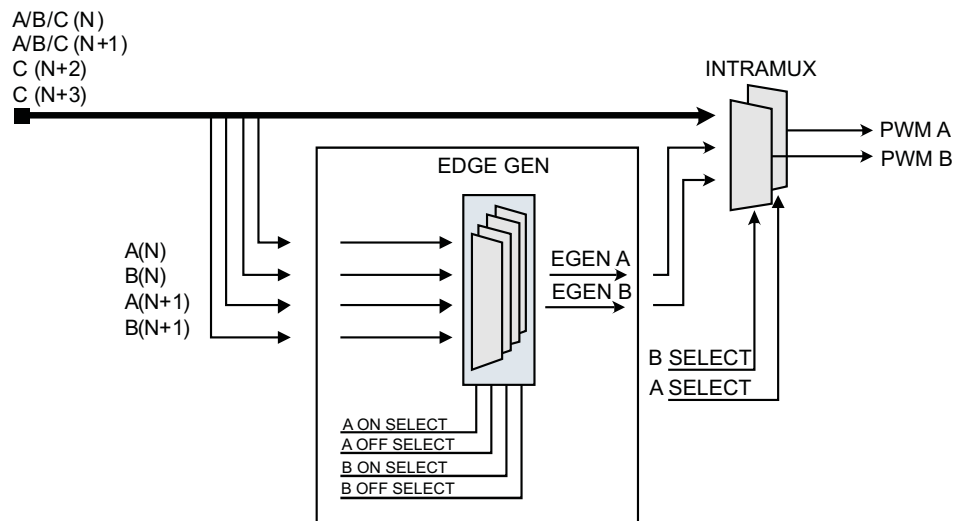

Figure 22. Edge Generation / IntraMux

Here is a list of the IntraMux modes for DPWMA:

- 0 = DPWMA(n) pass through (default)
- 1 = Edge-gen output, DPWMA(n)
- 2 = DPWNC(n)
- 3 = DPWMB(n) (Crossover)
- 4 = DPWMA(n+1)
- 5 = DPWMB(n+1)
- 6 = DPWMC(n+1)
- 7 = DPWMC(n+2)
- 8 = DPWMC(n+3)

and for DPWMB:

- 0 = DPWMB(n) pass through (default)
- 1 = Edge-gen output, DPWMB(n)
- 2 = DPWNC(n)
- 3 = DPWMA(n) (Crossover)
- 4 = DPWMA(n+1)
- 5 = DPWMB(n+1)

$$6 = \text{DPWMC}(n+1)$$

$$7 = \text{DPWMC}(n+2)$$

$$8 = \text{DPWMC}(n+3)$$

The DPWM number wraps around just like the Edge Gen unit. For DPWM3 the following definitions apply:

DPWM(n)	DPWM3
DPWM(n+1)	DPWM0
DPWM(n+2)	DPWM1
DPWM(n+3)	DPWM2

### 9.3.5 Synchronous Rectifier MOSFET Ramp And IDE Calculation

The device has built in logic for optimizing the performance of the synchronous rectifier MOSFETs. This comes in two forms:

- Synchronous Rectifier MOSFET ramp for softly turning on and off the MOSFETs
- Ideal Diode Emulation (IDE) calculation

When starting up a power supply, it is not uncommon for there to already be a voltage present on the output – this is called pre-bias. It can be very difficult to calculate the ideal synchronous rectifier MOSFET on-time for this case. If it is not calculated correctly, it may pull down the pre-bias voltage, causing the power supply to sink current. To avoid this, the synchronous rectifier MOSFETs are not turned on until after the power supply has ramped up to the nominal output voltage. The synchronous rectifier MOSFETs are then turned on slowly in order to avoid an output voltage glitch. The synchronous rectifier MOSFET ramp logic can be used to turn them on at a rate well below the bandwidth of the filter.

In discontinuous mode, the ideal on-time for the synchronous rectifier MOSFETs is a function of  $V_{in}$ ,  $V_{out}$ , and the primary side duty cycle (D). The IDE logic in the UCD3138xA takes  $V_{in}$  and  $V_{out}$  data from the firmware and combines it with D data from the filter hardware. It uses this information to calculate the ideal on-time for the synchronous rectifier MOSFETs.

### 9.3.6 Filter

The UCD3138xA filter is a PID filter with many enhancements for power supply control. Some of its features include:

- Traditional PID Architecture
- Programmable non-linear limits for automated modification of filter coefficients based on received EADC error
- Multiple coefficient sets fully configurable by firmware
- Full 24-bit precision throughout filter calculations
- Programmable clamps on integrator branch and filter output
- Ability to load values into internal filter registers while system is running
- Ability to stall calculations on any of the individual filter branches
- Ability to turn off calculations on any of the individual filter branches
- Duty cycle, resonant period, or phase shift generation based on filter output.
- Flux balancing
- Voltage feed forward

Here is the first section of the Filter :

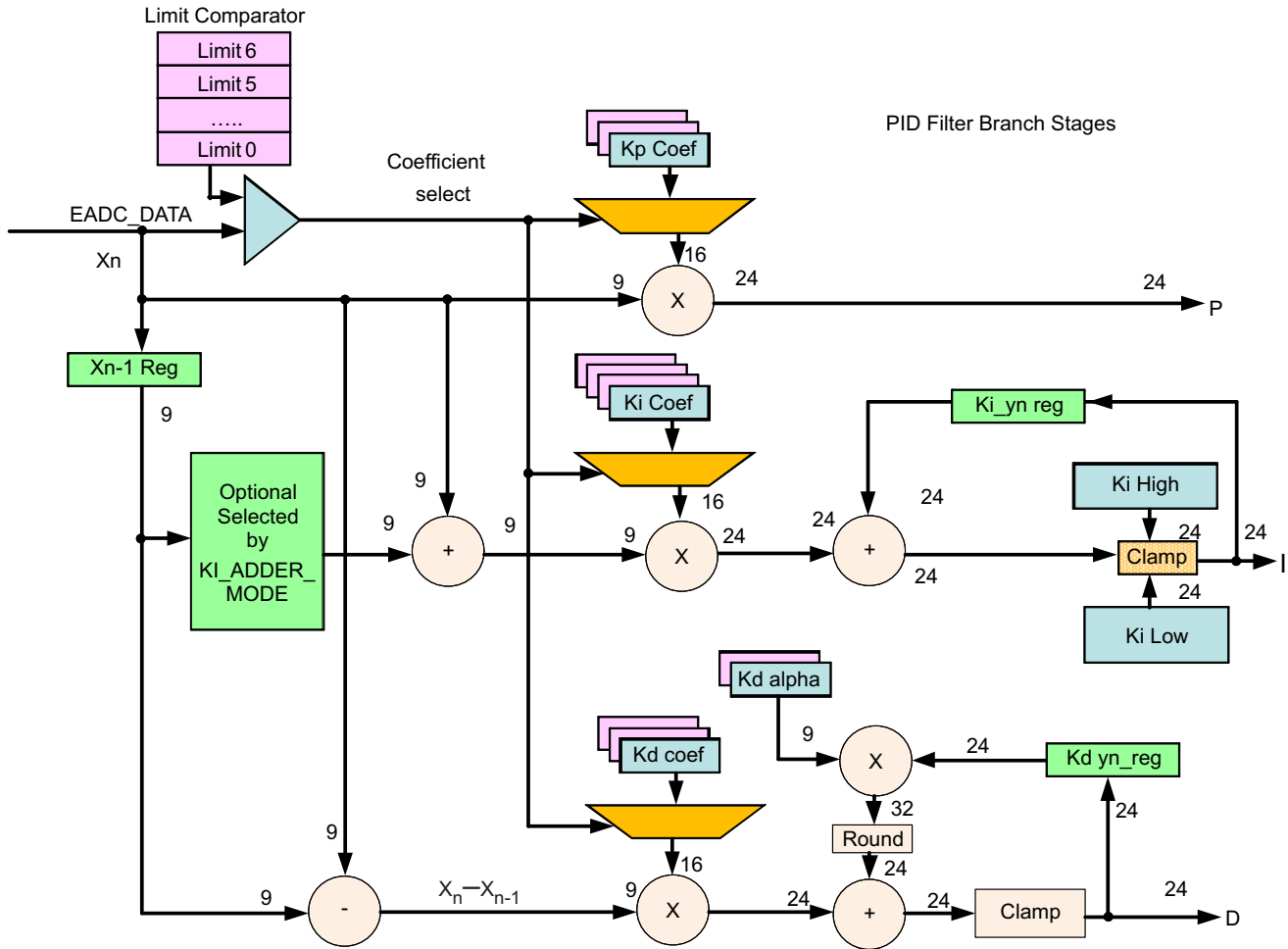

Figure 23. First Section of the Filter

The filter input,  $X_n$ , generally comes from a front end. Then there are three branches, P, I, and D. Note that the D branch also has a pole, Kd Alpha. Clamps are provided both on the I branch and on the D alpha pole.

The filter also supports a nonlinear mode, where up to 7 different sets of coefficients can be selected depending on the magnitude of the error input  $X_n$ . This can be used to increase the filter gain for higher errors to improve transient response.

Here is the output section of the filter (S0.23 means that there is 1 sign bit, 0 integer bits and 23 fractional bits).

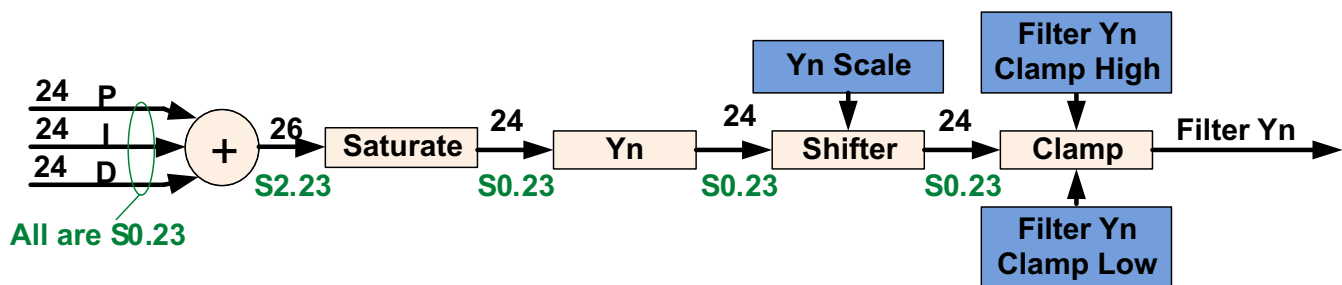

Figure 24. Output Section of the Filter

This section combines the P, I, and D sections, and provides for saturation, scaling, and clamping.

There is a final section for the filter, which permits its output to be matched to the DPWM:

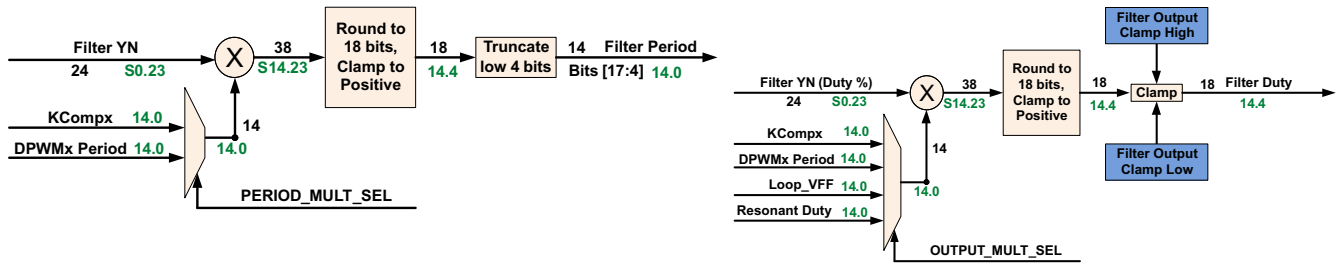

Figure 25. Final Section for the Filter

This permits the filter output to be multiplied by a variety of correction factors to match the DPWM Period, to provide for Voltage Feed Forward, or for other purposes. After this, there is another clamp. For resonant mode, the filter can be used to generate both period and duty cycle.

### 9.3.6.1 Loop Multiplexer

The Loop Mux controls interconnections between the filters, front ends, and DPWMs. Any filter, front end, and DPWM can be combined in a variety of configurations.

It also controls the following connections:

- DPWM to Front End
- Front End DAC control from Filters or Constant Current/Constant Power Module
- Filter Special Coefficients and Feed Forward
- DPWM synchronization
- Filter to DPWM

The following control modules are configured in the Loop Mux:

- Constant Power/Constant Current
- Cycle Adjustment (Current and flux balancing)
- Global Period
- Light Load (Burst Mode)
- Analog Peak Current Mode

### 9.3.6.2 Fault Multiplexer

In order to allow a flexible way of mapping several fault triggering sources to all the DPWMs channels, the UCD3138xA provides an extensive array of multiplexers that are united under the name Fault Mux module.

The Fault Mux Module supports the following types of mapping between all the sources of fault and all the different fault response mechanisms inside each DPWM module.

- Many fault sources may be mapped to a single fault response mechanism. For instance an analog comparator in charge of over voltage protection, a digital comparator in charge of over current protection and an external digital fault pin can be all mapped to a Fault-A signal connected to a single FAULT MODULE and shut down DPWM1-A.
- A single fault source can be mapped to many fault response mechanisms inside many DPWM modules. For instance an analog comparator in charge of over current protection can be mapped to DPWM-0 through DPWM-3 by way of several fault modules.
- Many fault sources can be mapped to many fault modules inside many DPWM modules.

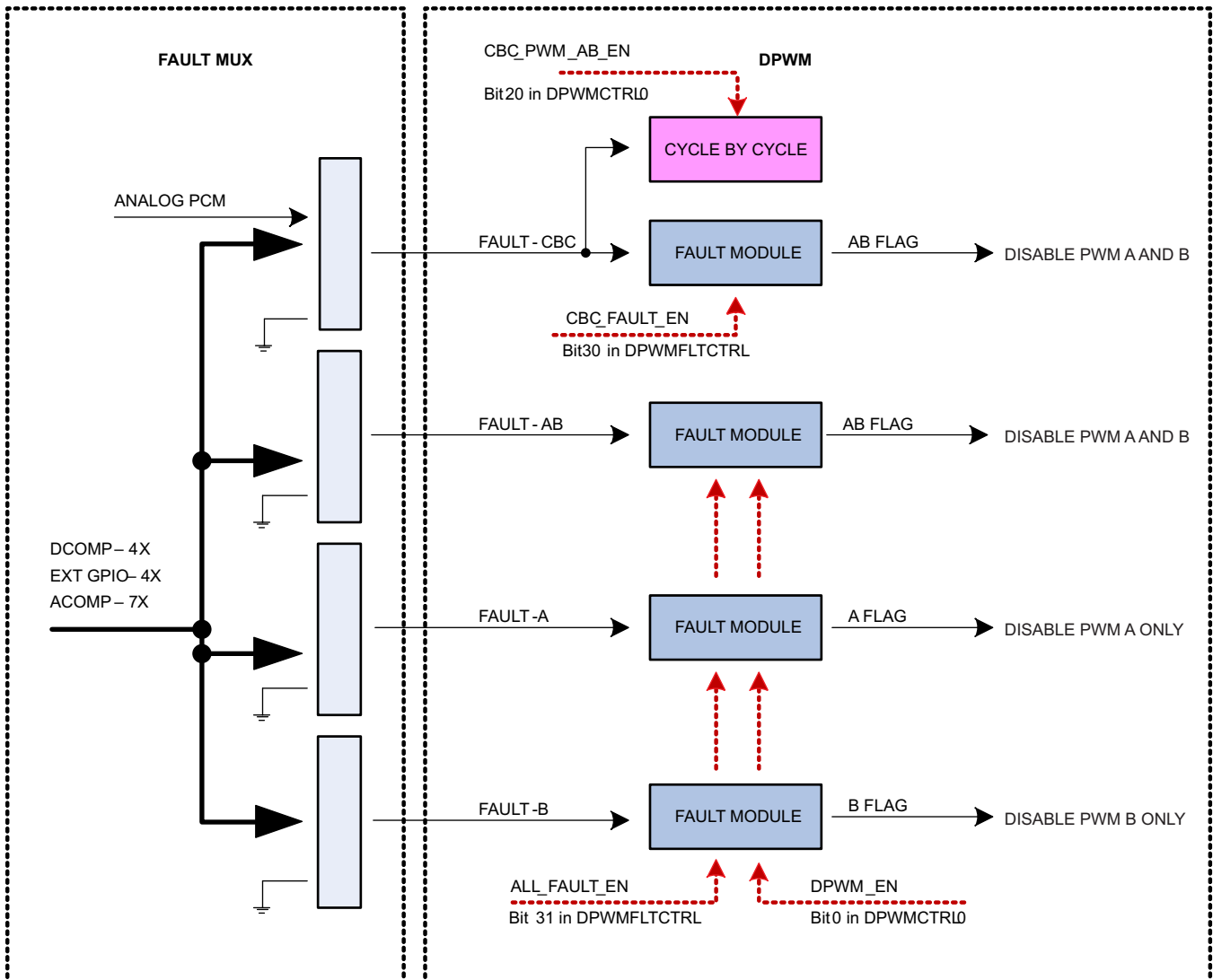
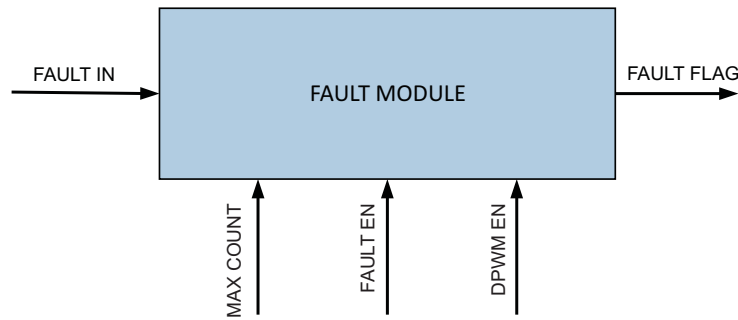

Figure 26. Fault Mux Module

The Fault Mux Module provides a multitude of fault protection functions within the UCD3138xA high-speed loop (Front End Control, Filter, DPWM and Loop Mux modules). The Fault Mux Module allows highly configurable fault generation based on digital comparators, high-speed analog comparators and external fault pins. Each of the fault inputs to the DPWM modules can be configured to one or any combination of the fault events provided in the Fault Mux Module.

Each one of the DPWM engines has four fault modules. The modules are called CBC fault module, AB fault module, A fault module and B fault module.

The internal circuitry in all the four fault modules is identical, and the difference between the modules is limited to the way the modules are attached to the DPWMs.

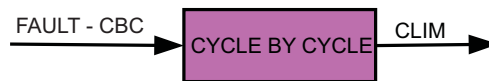

**Figure 27. Fault Module**

All fault modules provide immediate fault detection but only once per DPWM switching cycle. Each one of the fault modules own a separate max\_count and the fault flag will be set only if sequential cycle-by-cycle fault count exceeds max\_count.

Once the fault flag is set, DPWMs need to be disabled by DPWM\_EN going low in order to clear the fault flags. Please note, all four Fault Modules share the same DPWM\_EN control, all fault flags (output of Fault Modules) will be cleared simultaneously.

All four Fault Modules share the same global FAULT\_EN as well. Therefore a specific Fault Module cannot be enabled/ disabled separately.



**Figure 28. Cycle-By-Cycle Block**

Unlike Fault Modules, only one Cycle by Cycle block is available in each DPWM module.

The Cycle by Cycle block works in conjunction with CBC Fault Module and enables DPWM reaction to signals arriving from the Analog Peak current mode (PCM) module.

The Fault Mux Module supports the following basic functions:

- 4 digital comparators with programmable thresholds and fault generation
- Configuration for 7 high speed analog comparators with programmable thresholds and fault generation
- External GPIO detection control with programmable fault generation
- Configurable DPWM fault generation for DPWM Current Limit Fault, DPWM Over-Voltage Detection Fault, DPWM A External Fault, DPWM B External Fault and DPWM IDE Flag
- Clock Failure Detection for High and Low Frequency Oscillator blocks and XTAL failure
- Discontinuous Conduction Mode Detection

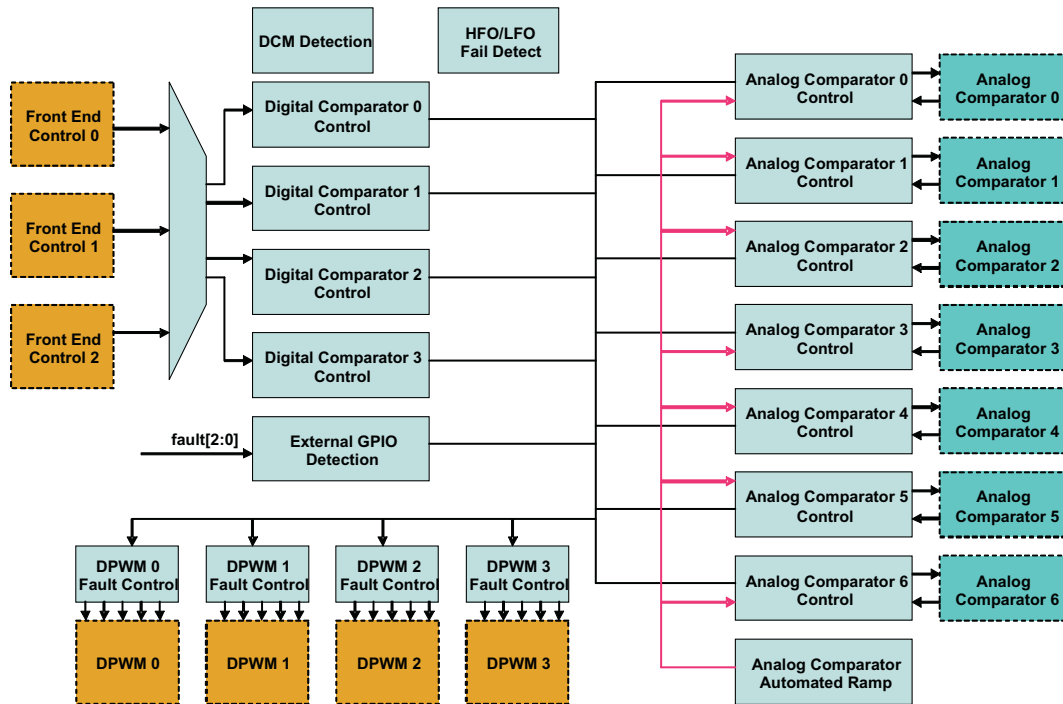

Figure 29. Fault Mux Block Diagram

### 9.3.7 Communication Ports

#### 9.3.7.1 SCI (UART) Serial Communication Interface

A maximum of two independent Serial Communication Interface (SCI) or Universal Asynchronous Receiver/Transmitter (UART) interfaces are included within the device for asynchronous start-stop serial data communication (see the pin out sections for details). Each interface has a 24 bit pre-scaler for supporting programmable baud rates, a programmable data word and stop bit options. Half or full duplex operation is configurable through register bits. A loop back feature can also be setup for firmware verification. Both SCI-TX and SCI-RX pin sets can be used as GPIO pins when the peripheral is not being used.

#### 9.3.7.2 PMBUS/I<sup>2</sup>C

The UCD3138xA has two independent interfaces which both support PMBus and I<sup>2</sup>C in master and slave modes. Only one of the interfaces has control of the address pin current sources as well as support for the optional Control and Alert lines described in the PMBus specification. Other than these differences, the interfaces are identical.

The PMBus/I<sup>2</sup>C interface is designed to minimize the processor overhead required for interface. It can automatically detect and acknowledge addresses. It handles start and stop conditions automatically, and can clock stretch until the processor has time to poll the PMBus status. It will automatically receive and send up to 4 bytes at a time. It can automatically verify and generate a PEC. This means that a write byte command can be received by the processor with only one function call.

The interface also supports automatic ACK of two independent addresses. If both PMBus/I<sup>2</sup>C interfaces are used at the same time a total of 4 independent addresses can be automatically detected.

### 9.3.7.2.1 Example: PMBus Address Decode via ADC12 Reading

The user can allocate 2 pins of the 12-bit ADC input channels, AD\_00 and AD\_01, for PMBus address decoding. At power-up the device applies  $I_{BIAS}$  to each address detect pin and the voltage on that pin is captured by the internal 12-bit ADC.

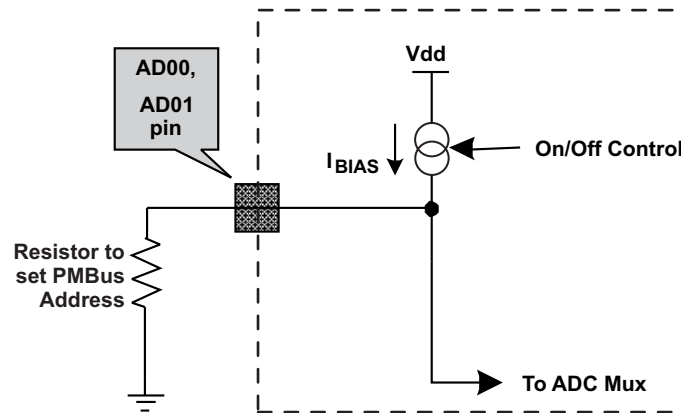
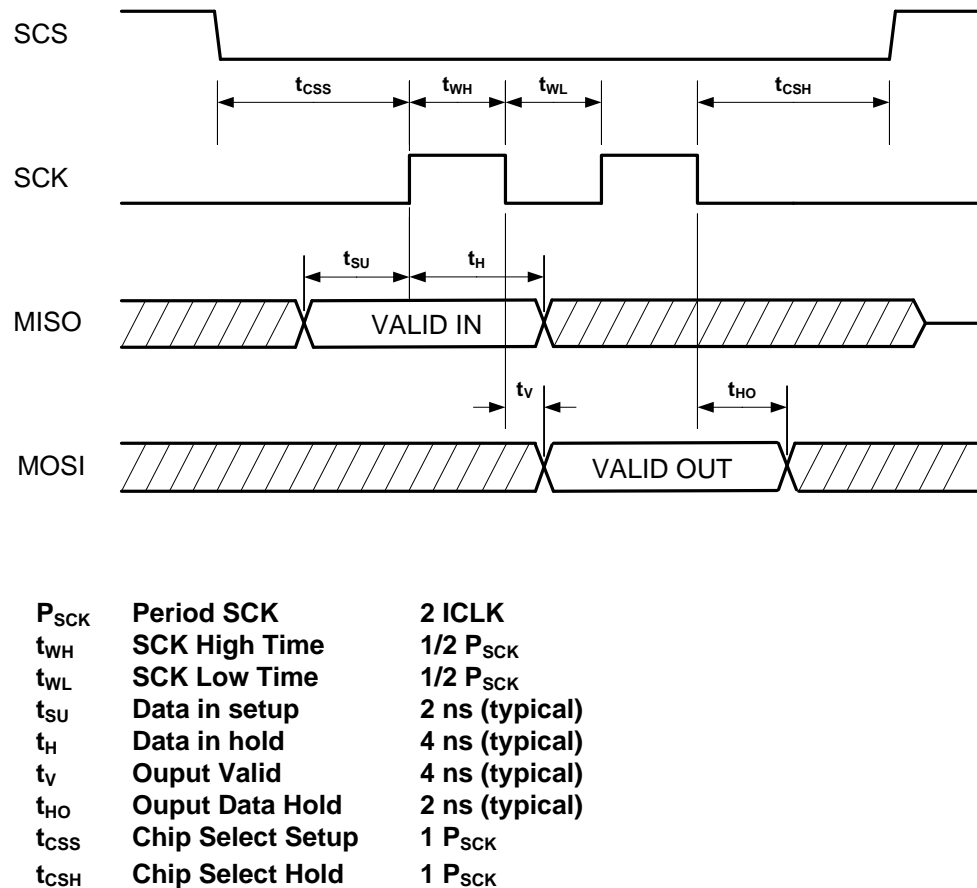

**Figure 30. PMBUS Address Detection Method**

PMBus/I<sup>2</sup>C address 0x7E is a reserved address and should not be used in a system using the UCD3138xA. This address is used for manufacturing test.

### 9.3.7.3 SPI

The SPI is a high-speed synchronous serial input/output port that allows a serial bit stream of programmed length (1 to 16 bits) to be shifted into and out of the device at a programmed bit-transfer rate. The SPI is normally used for communication between the UCD3138xA and external peripherals. Typical applications include an interface to external I/O or peripheral expansion via devices such as shift registers, display drivers, SPI EPROMs and analog-to-digital converters. The SPI allows serial communication with other SPI devices through a 3-pin or 4-pin mode interface. A typical use case of SPI is to be configured as a master for communicating to external EEPROM.

**Figure 31. SPI Timing Diagram**

#### 9.3.7.4 JTAG Standard Interface

The UCD31xx family provides an On-Chip Scan-Base Emulation Logic, IEEE standard 1149.1 JTAG interface which requires four signals for debugging and flash programming purposes. The JTAG pins are shared with other function specific or general purpose I/O. The IOMUX register controls the JTAG pin sharing mechanism. The *Pin Functions* table in [Pin Configuration and Functions](#) lists the JTAG pin requirements. For further details on interfacing to development tools and device programmers, see the UCD31xx Technical reference Manual ([SLUSAP2](#)).

#### 9.3.8 Real Time Clock

The UCD3138xA has an internal real time clock (RTC) function that can track time in seconds, minutes, hours and days. This function requires an external precision 10 MHz clock.

- Firmware writable time/day register which tracks the total number of days.
  - The day counter will be able to count 4 years worth of days.
  - Years and months and leap year calculation must be calculated in firmware.
- Firmware programmable frequency correction of  $\pm 200$  ppm in 0.8 ppm steps
- The RTC function can provide interrupts to the IRQ or FIQ at 1, 10, 30, and 60 second intervals.
- The clock from the RTC driver can be driven to an external pin through an internal multiplexor
- The clock for the RTC function can come from an external clock through a dedicated GPIO pin.

#### 9.3.9 External Crystal Interface

The UCD3138128A supports a 10-MHz external crystal. The external crystal can be used for the Real Time Clock or synthesized to be the system clock.

The crystal circuit biasing should be optimized depending on the total  $C_{load}$  on the crystal. Refer to [Table 5](#) for recommended bias settings based on  $C_{load}$ .

**Table 5. Recommended Bias Settings**

$C_{load}$	BIAS_R SETTING
0~4pF	0
5~7pF	1
8~11pF	2
12~15pF	3
16~20pF	4

### 9.3.10 Timers

External to the Digital Power Peripherals there are 3 different types of timers in UCD3138xA. They are the 24-bit timer, 16-bit timer and the watchdog timer

#### 9.3.10.1 24-Bit Timer

There is one 24 bit timer which runs off the Interface Clock. It can be used to measure the time between two events, and to generate interrupts after a specific interval. Its clock can be divided down by an 8-bit pre-scaler to provide longer intervals. The timer has two compare registers (Data Registers). Both can be used to generate an interrupt after a time interval. . Additionally, the timer has a shadow register (Data Buffer register) which can be used to store CPU updates of the compare events while still using the timer. The selected shadow register update mode happens after the compare event matches.

The two capture pins TCAP0 and TCAP1 are inputs for recording a capture event. A capture event can be set either to rising, falling, or both edges of the capture pin signal. Upon this event, the counter value is stored in the corresponding capture data register. Five Interrupts from the 24 bit timer can be set, which are the counter rollover event (overflow), capture events 0 and 1, and the two comparison match events. Each interrupt can be disabled or enabled.

#### 9.3.10.2 16-Bit PWM Timers

There are four 16 bit counter PWM timers which run off the Interface Clock and can further be divided down by a 8-bit pre-scaler to generate slower PWM time periods. Each timer has two compare registers (Data Registers) for generating the PWM set/unset events. Additionally, each timer has a shadow register (Data Buffer register) which can be used to store CPU updates of compare events while still using the timer. The selected shadow register update mode happens after the compare event matches.

The counter reset can be configured to happen on a counter roll over, a compare equal event, or by a software controlled register. Interrupts from the PWM timer can be set due to the counter rollover event (overflow) or by the two comparison match events. Each comparison match and the overflow interrupts can be disabled or enabled.

Upon an event comparison, the PWM pin can be configured to set, clear, toggle or have no action at the output. The value of PWM pin output can be read for status or simply configured as General Purpose I/O for reading the value of the input at the pin.

#### 9.3.10.3 Watchdog Timer

A watchdog timer is provided on the device for ensuring proper firmware loop execution. The timer is clocked off of a separate low speed oscillator source. If the timer is allowed to expire, a reset condition is issued to the ARM processor. The watchdog is reset by a simple CPU write bit to the watchdog key register by the firmware routine. On device power-up the watchdog is disabled. Yet after it is enabled, the watchdog cannot be disabled by firmware. Only a device reset can put this bit back to the default disabled state. A half timer flag is also provided for status monitoring of the watchdog.

### 9.3.11 General Purpose ADC12

The ADC12 is a 12 bit, high speed analog to digital converter, equipped with the following options:

- Typical conversion speed of 539 ksp/s
- Conversions can consist from 1 to 16 ADC channel conversions in any desired sequence

- Post conversion averaging capability, ranging from 4X, 8X, 16X or 32X samples
- Configurable triggering for ADC conversions from the following sources: firmware, DPWM rising edge, ADC\_EXT\_TRIG pin or Analog Comparator results
- Interrupt capability to embedded processor at completion of ADC conversion
- Six digital comparators on the first 6 channels of the conversion sequence using either raw ADC data or averaged ADC data
- Two 10  $\mu$ A current sources for excitation of PMBus addressing resistors
- Dual sample and hold for accurate power measurement
- Internal temperature sensor for temperature protection and monitoring

The control module (*ADC12 Control Block Diagram*) contains the control and conversion logic for auto-sequencing a series of conversions. The sequencing is fully configurable for any combination of 16 possible ADC channels through an analog multiplexer embedded in the ADC12 block. Once converted, the selected channel value is stored in the result register associated with the sequence number. Input channels can be sampled in any desired order or programmed to repeat conversions on the same channel multiple times during a conversion sequence. Selected channel conversions are also stored in the result registers in order of conversion, where the result 0 register is the first conversion of a 16-channel sequence and result 15 register is the last conversion of a 16-channel sequence. The number of channels converted in a sequence can vary from 1 to 16.

Unlike EADC0 through EADC2, which are primarily designed for closing high speed compensation loops, the ADC12 is not usually used for loop compensation purposes. The EADC converters have a substantially faster conversion rate, thus making them more attractive for closed loop control. The ADC12 features make it best suited for monitoring and detection of currents, voltages, temperatures and faults. Please see the *Typical Characteristics plots* for the temperature variation associated with this function.

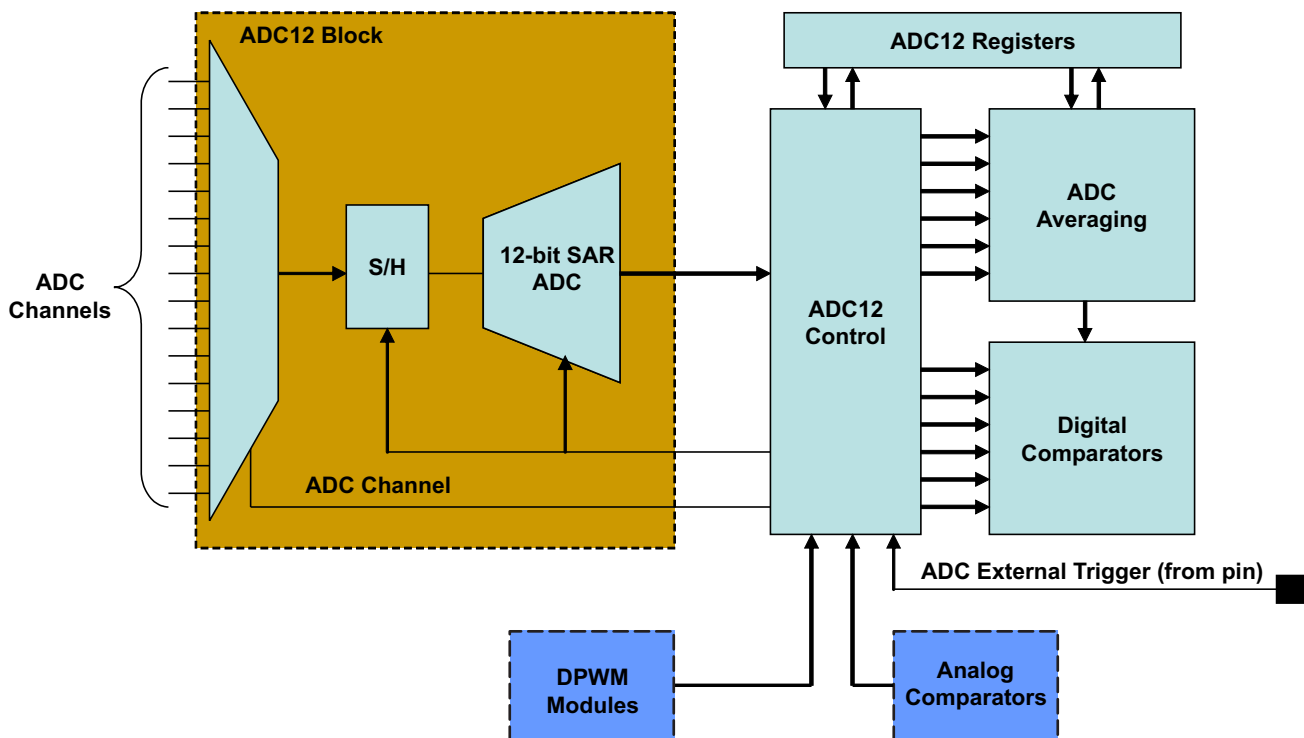

Figure 32. ADC12 Control Block Diagram

### 9.3.12 Miscellaneous Analog

The Miscellaneous Analog Control (MAC) Registers control and monitor a wide variety of functions. These functions include device supervisory features such as Brown-Out and power saving configuration, general purpose input/output configuration and interfacing, internal temperature sensor control and current sharing control.

**UCD3138128A**

SLUSC99A – JULY 2016 – REVISED JANUARY 2017

[www.ti.com](http://www.ti.com)

---

The MAC module also provides trim signals to the oscillator and AFE blocks. These controls are usually used at the time of trimming at manufacturing; therefore this document will not cover these trim controls.

### 9.3.13 Brownout

Brownout function is used to determine if the device supply voltage is lower than a threshold voltage, a condition that may be considered unsafe for proper operation of the device.

The brownout threshold is higher than the reset threshold voltage; therefore, when the supply voltage is lower than brownout threshold, it still does not necessarily trigger a device reset.

The brownout interrupt flag can be polled or alternatively can trigger an interrupt to service such case by an interrupt service routine. Please see the [Power On Reset \(POR\) / Brown Out Reset \(BOR\)](#) section.

### 9.3.14 Global I/O

Up to 32 pins in UCD3138xA can be configured in the Global I/O register to serve as a general purpose input or output pins (GPIO). This includes all digital input or output pins except for the RESET pin.

The pins that cannot be configured as GPIO pins are the supply pins, ground pins, ADC-12 analog input pins, EADC analog input pins and the RESET pin. Additional digital pins not listed in this register can be configured through their local configuration registers.

There are two ways to configure and use the digital pins as GPIO pins:

1. Through the centralized Global I/O control registers.
2. Through the distributed control registers in the specific peripheral that shares it pins with the standard GPIO functionality.

The Global I/O registers offer full control of:

1. Configuring each pin as a GPIO.
2. Setting each pin as input or output.
3. Reading the pin's logic state, if it is configured as an input pin.
4. Setting the logic state of the pin, if it is configured as an output pin.
5. Connecting pin/pins to high rail through internal push/pull drivers or external pull up resistors.

The Global I/O registers include Global I/O EN register, Global I/O OE Register, Global I/O Open Drain Control Register, Global I/O Value Register and Global I/O Read Register.

[Table 6](#) shows the format of Global I/O EN Register (GLBIOEN) as an example:

**Table 6. Global I/O EN Register (GLBIOEN)**

BIT NUMBER	31:0
Bit Name	GLOBAL_IO_EN
Access	R/W
Default	0000_0000_0000_0000_0000_0000_0000

**Bits 31-0: GLOBAL\_IO\_EN** – This register enables the global control of digital I/O pins

0 = Control of IO is done by the functional block assigned to the IO (Default)

1 = Control of IO is done by Global IO registers.

BIT	PIN_NAME	PIN NUMBER
		UCD3138xA
31	PWM2	11
30	PWM3	12
29	FAULT3	55
28	ADC_EXT_TRIG	14
27	TCK	45
26	TDO	46
25	TMS	48
24	TDI	47
23	SCI_TX1	37
22	SCI_TX0	35

BIT	PIN_NAME	PIN NUMBER
		UCD3138xA
21	SCI_RX1	38
20	SCI_RX0	36
19	TCAP0	49
18	PWM1	40
17	PWM0	39
16	TCAP1	13
15	I2C_DATA	20
14	PMBUS_CTRL	18
13	PMBUS_ALERT	17
12	EXT_INT	42
11	FAULT2	54
10	FAULT1	44
9	FAULT0	43
8	SYNC	34
7	DPWM3B	29
6	DPWM3A	28
5	DPWM2B	27
4	DPWM2A	26
3	DPWM1B	25
2	DPWM1A	24
1	DPWM0B	23
0	DPWM0A	22

### 9.3.15 Temperature Sensor Control

Temperature sensor control register provides internal temperature sensor enabling and trimming capabilities. The internal temperature sensor is disabled by default.

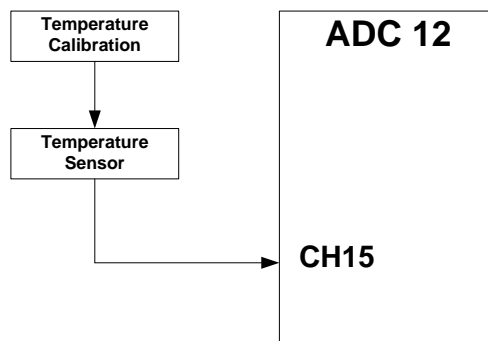

**Figure 33. Internal Temp Sensor**

Temperature sensor is calibrated at room temperature (25 °C) via a calibration register value.

The temperature sensor is measured using ADC12 (via Ch15). The temperature is then calculated using a mathematical formula involving the calibration register (this effectively adds a delta to the ADC measurement).

The temperature sensor can be enabled or disabled.

### 9.3.16 I/O Mux Control

I/O Mux Control register may be used in order to choose a single specific functionality that is desired to be assigned to a physical device pin for your application. See the UCD3138xA programmer's manual for details on the available configurations.

### 9.3.17 Current Sharing Control

UCD3138xA provides three separate modes of current sharing operation.

- Analog bus current sharing
- PWM bus current sharing
- Master/Slave current sharing
- AD02 has a special ESD protection mechanism that prevents the pin from pulling down the current-share bus if power is missing from the UCD3138xA

The simplified current sharing circuitry is shown in the drawing below. The digital pulse connected to SW3 transforms SW3 into a pulse-width-modulated current source. Details on the frequency and resolution of this feature are in the digital power fusion peripherals manual.

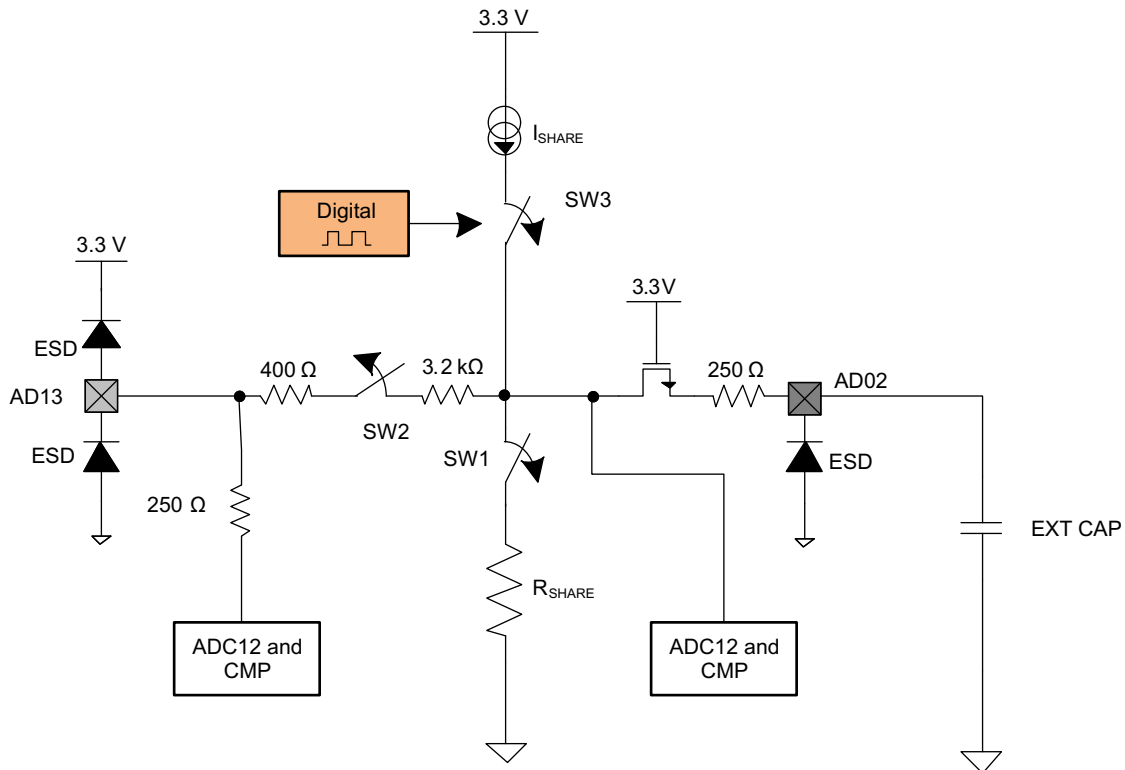

Copyright © 2016, Texas Instruments Incorporated

Figure 34. Simplified Current Sharing Circuitry

CURRENT SHARING MODE	FOR TEST ONLY, ALWAYS KEEP 00	CS_MODE	EN_SW1	EN_SW2	DPWM
Off or Slave Mode (3-state)	00	00 (default)	0	0	0
PWM Bus	00	01	1	0	ACTIVE
Off or Slave Mode (3-state)	00	10	0	0	0
Analog Bus or Master	00	11	0	1	0

The period and the duty of 8-bit PWM current register and the state of the SW1 and SW2 switches can be controlled through the current sharing control register (CSCTRL).

### 9.3.18 Temperature Reference

The temperature reference register (TEMPREF) provides the ADC12 count when ADC12 measures the internal temperature sensor (channel 15) during the factory trim and calibration.

This information can be used by different periodic temperature compensation routines implemented in the firmware. But it should not be overwritten by firmware, otherwise this factory written value will be lost until the device is reset.

## 9.4 Device Functional Modes

### 9.4.1 DPWM Modes of Operation

The DPWM is a complex logic system which is highly configurable to support several different power supply topologies. The discussion below will focus primarily on waveforms, timing and register settings, rather than on logic design.

The DPWM is centered on a period counter, which counts up from 0 to PRD, and then is reset and starts over again.

The DPWM logic causes transitions in many digital signals when the period counter hits the target value for that signal.

#### 9.4.1.1 Normal Mode

In Normal mode, the Filter output determines the pulse width on DPWM A. DPWM B fits into the rest of the switching period, with a dead time separating it from the DPWM A on-time. It is useful for buck topologies. The drawing of the Normal Mode waveforms is shown in [Figure 35](#).

Cycle adjust A can be used to adjust pulse widths on individual phases of a multi-phase system. This can be used for functions like current balancing. The Adaptive Sample Triggers can be used to sample in the middle of the on-time (for an average output), or at the end of the on-time (to minimize phase delay) The Adaptive Sample Register provides an offset from the center of the on-time. This can compensate for external delays, such as MOSFET and gate driver turn on times.

Blanking A-Begin and Blanking A-End can be used to blank out noise from the MOSFET turn on at the beginning of the period (DPWMA rising edge). Blanking B could be used at the turn off time of DPWMB. The other edges are dynamic, so blanking is more difficult.

Cycle Adjust B has no effect in Normal Mode.

Device Functional Modes (continued)

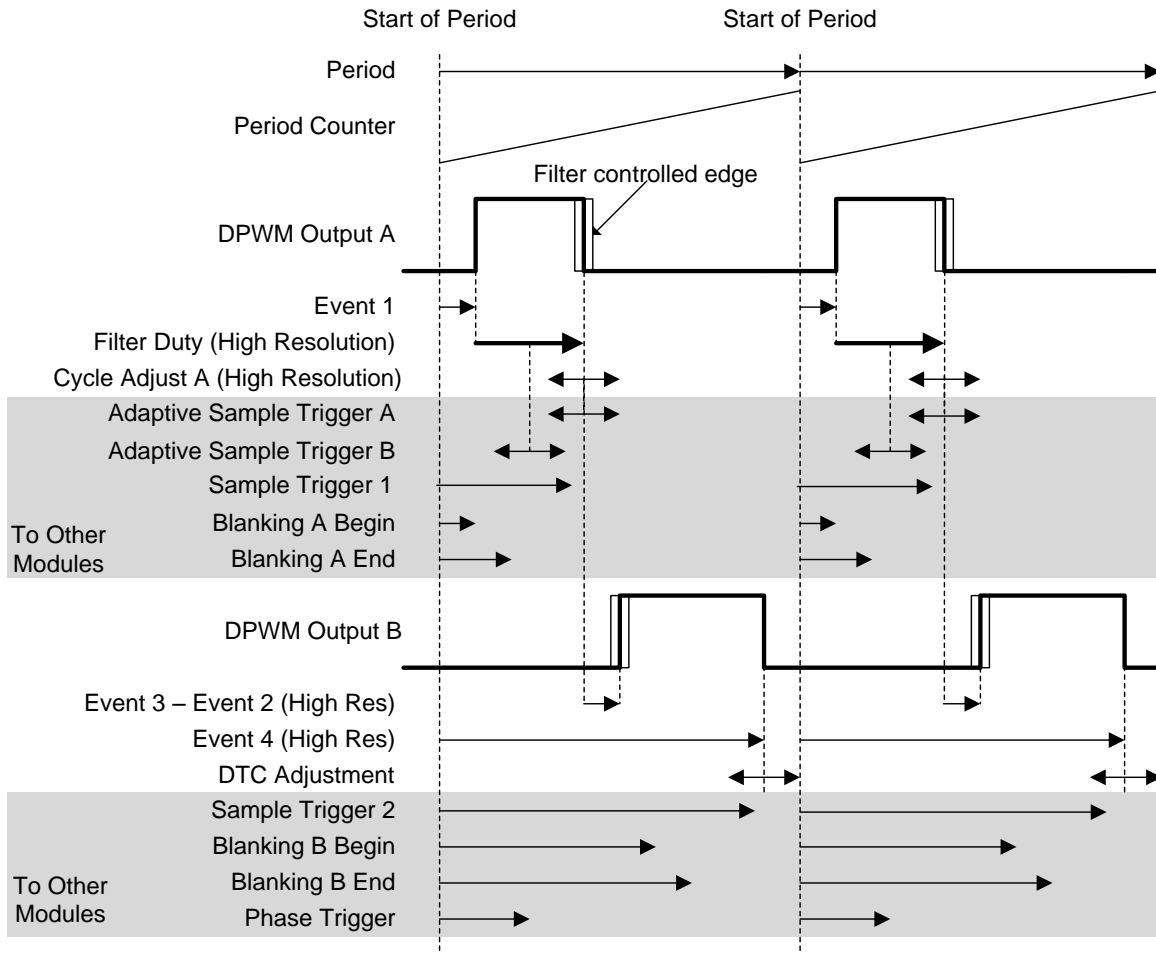

Events which change with DPWM mode:

- DPWM A Rising Edge = Event 1
- DPWM A Falling Edge = Event 1 + Filter Duty + Cycle Adjust A
- Adaptive Sample Trigger A = Event 1 + Filter Duty + Adaptive Sample Register or
- Adaptive Sample Trigger B = Event 1 + Filter Duty/2 + Adaptive Sample Register
- DPWM B Rising Edge = Event 1 + Filter Duty + Cycle Adjust A + (Event 3 – Event 2)
- DPWM B Falling Edge = Event 4 + DTC Adjustment
- Phase Trigger = Phase Trigger Register value or Filter Duty

Events always set by their registers, regardless of mode:

- Sample Trigger 1, Sample Trigger 2, Blanking A Begin, Blanking A End, Blanking B Begin, Blanking B End

Figure 35. Normal Mode Closed Loop

## Device Functional Modes (continued)

### 9.4.1.2 DPWM Multiple Output Mode

Multi mode is used for systems where each phase has only one driver signal. It enables each DPWM peripheral to drive two phases with the same pulse width, but with a time offset between the phases, and with different cycle adjusts for each phase.

The diagram for Multi-Mode is shown in [Figure 36](#).

Event 2 and Event 4 are not relevant in Multi mode.

DPWMB can cross over the period boundary safely, and still have the proper pulse width, so full 100% pulse width operation is possible. DPWMA cannot cross over the period boundary.

Since the rising edge on DPWM B is also fixed, Blanking B-Begin and Blanking B-End can be used for blanking this rising edge.

Cycle Adjust B is usable on DPWM B.

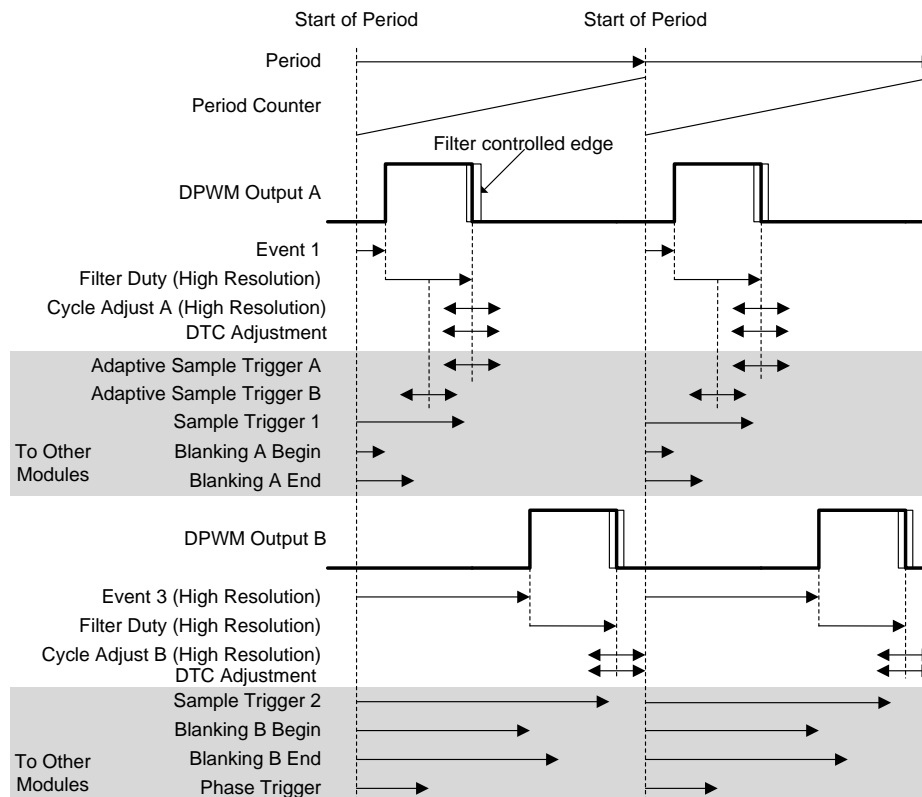

Events which change with DPWM mode:

- DPWM A Rising Edge = Event 1
- DPWM A Falling Edge = Event 1 + Filter Duty + Cycle Adjust A + DTC Adjustment
- Adaptive Sample Trigger A = Event 1 + Filter Duty + Adaptive Sample Register or
- Adaptive Sample Trigger B = Event 1 + Filter Duty/2 + Adaptive Sample Register
- DPWM B Rising Edge = Event 3
- DPWM B Falling Edge = Event 3 + Filter Duty + Cycle Adjust B + DTC Adjustment
- Phase Trigger = Phase Trigger Register value or Filter Duty

Events always set by their registers, regardless of mode:

- Sample Trigger 1, Sample Trigger 2, Blanking A Begin, Blanking A End, Blanking B Begin, Blanking B End

**Figure 36. Multi Mode Closed Loop**

## Device Functional Modes (continued)

### 9.4.1.3 DPWM Resonant Mode

This mode provides a symmetrical waveform where DPWMA and DPWMB have the same pulse width. As the switching frequency changes, the dead times between the pulses remain the same.

The equations for this mode are designed for a smooth transition from PWM mode to resonant mode, as described in [LLC Example](#). The diagram of this mode is shown in [Figure 37](#).

The Filter has two outputs, Filter Duty and Filter Period. In this case, the Filter is configured so that the Filter Period is twice the Filter Duty. So if there were no dead times, each DPWM pin would be on for half of the period. For dead time handling, the average of the two dead times is subtracted from the Filter Duty for both DPWM pins. Therefore, both pins will have the same on-time, and the dead times will be fixed regardless of the period. The only edge which is fixed relative to the start of the period is the rising edge of DPWM A. This is the only edge for which the blanking signals can be used easily.

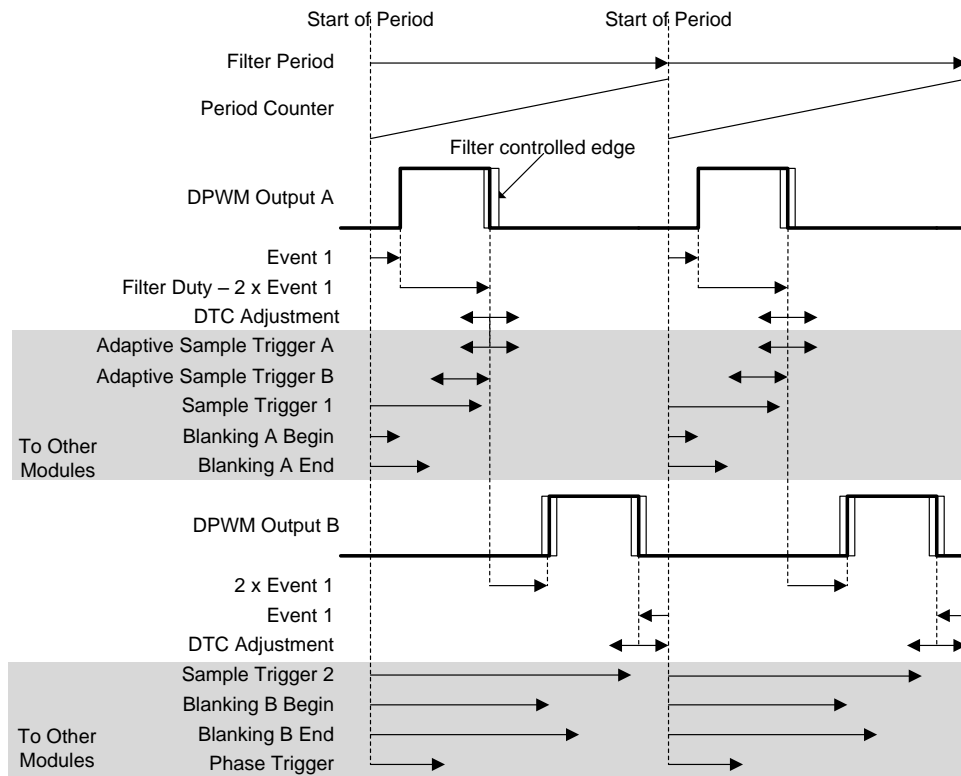

Events which change with DPWM mode:

- DPWM A Rising Edge = Event 1
- DPWM A Falling Edge = Filter Duty - Event 1 + DTC Adjustment
- Adaptive Sample Trigger A = Event 1 + Filter Duty + Adaptive Sample Register or
- Adaptive Sample Trigger B = Event 1 + Filter Duty/2 + Adaptive Sample Register
- DPWM B Rising Edge = Filter Duty + Event 1
- DPWM B Falling Edge = Filter Duty - Event 1 + DTC Adjustment
- Phase Trigger = Phase Trigger Register value or Filter Duty

Events always set by their registers, regardless of mode:

- Sample Trigger 1, Sample Trigger 2, Blanking A Begin, Blanking A End, Blanking B Begin, Blanking B End

**Figure 37. Resonant Symmetrical Closed Loop**

## Device Functional Modes (continued)

### 9.4.1.4 Triangular Mode

Triangular mode provides a stable phase shift in interleaved PFC and similar topologies. In this case, the PWM pulse is centered in the middle of the period, rather than starting at one end or the other. In Triangular Mode, only DPWM-B is available. The diagram for Triangular Mode is shown in [Figure 38](#).

All edges are dynamic in triangular mode, so fixed blanking is not that useful. The adaptive sample trigger is not needed. It is very easy to put a fixed sample trigger exactly in the center of the FET on-time, because the center of the on-time does not move in this mode.

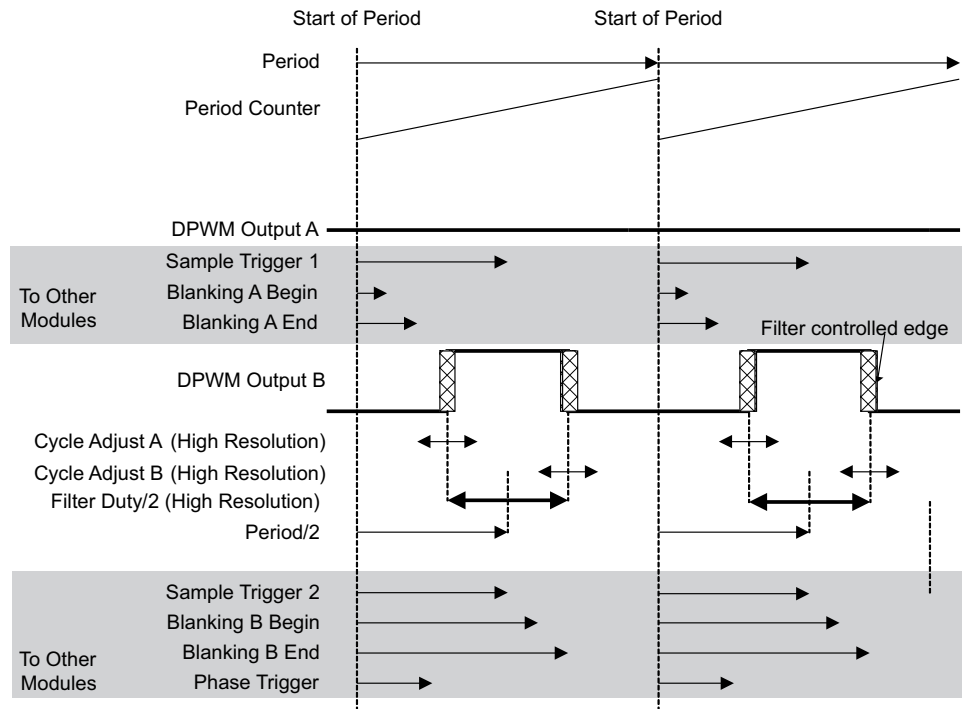

Events which change with DPWM mode:

- DPWM A Rising Edge = None
- DPWM A Falling Edge = None
- Adaptive Sample Trigger = None
- DPWM B Rising Edge =  $\text{Period} / 2 - \text{Filter Duty} / 2 + \text{Cycle Adjust A}$
- DPWM B Falling Edge =  $\text{Period} / 2 + \text{Filter Duty} / 2 + \text{Cycle Adjust B}$
- Phase Trigger = Phase Trigger Register value or Filter Duty

Events always set by their registers, regardless of mode:

- Sample Trigger 1, Sample Trigger 2, Blanking A Begin, Blanking A End, Blanking B Begin, Blanking B End
- Begin, Blanking B End

**Figure 38. Triangular Mode Closed Loop**

## Device Functional Modes (continued)

### 9.4.1.5 Leading Edge Mode

Leading edge mode is very similar to Normal mode, reversed in time. The DPWM A falling edge is fixed, and the rising edge moves to the left, or backwards in time, as the filter output increases. The DPWM B falling edge stays ahead of the DPWMA rising edge by a fixed dead time. The diagram of the Leading Edge Mode is shown in Figure 39.

As in the Normal mode, the two edges in the middle of the period are dynamic, so the fixed blanking intervals are mainly useful for the edges at the beginning and end of the period.

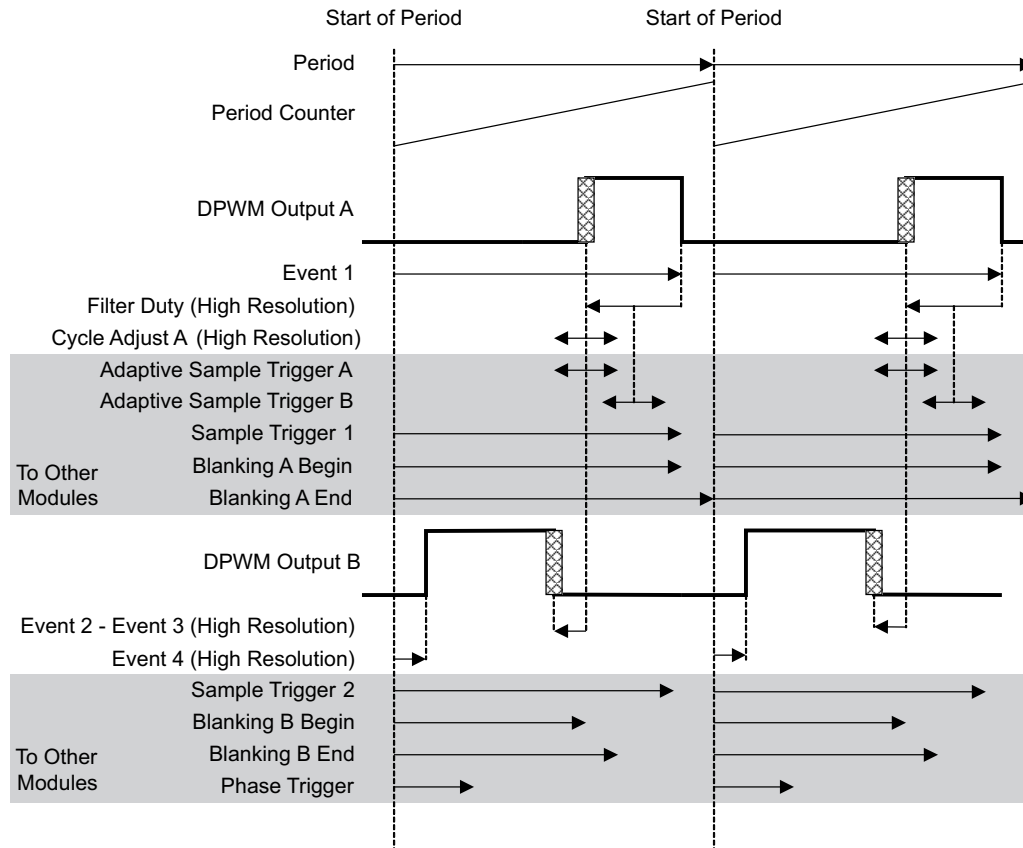

Events which change with DPWM mode:

- DPWM A Rising Edge = Event 1
- DPWM A Falling Edge = Event 1 - Filter Duty + Cycle Adjust A
- Adaptive Sample Trigger A = Event 1 - Filter Duty + Adaptive Sample Register or
- Adaptive Sample Trigger B = Event 1 - Filter Duty / 2 + Adaptive Sample Register
- DPWM B Rising Edge = Event 4
- DPWM B Falling Edge = Event 1 - Filter Duty + Cycle Adjust A - (Event 2 – Event 3)
- Phase Trigger = Phase Trigger Register value or Filter Duty

Events always set by their registers, regardless of mode:

- Sample Trigger 1, Sample Trigger 2, Blanking A Begin, Blanking A End, Blanking B Begin, Blanking B End
- Blanking B End

**Figure 39. Leading Edge Closed Loop**

## Device Functional Modes (continued)

### 9.4.1.6 Phase Shifting

In most modes, it is possible to synchronize multiple DPWM modules using the phase shift signal. The phase shift signal has two possible sources. It can come from the Phase Trigger Register. This provides a fixed value, which is useful for an application like interleaved PFC.

The phase shift value can also come from the filter output. In this case, the changes in the filter output causes changes in the phase relationship of two DPWM modules. This is useful for phase shifted full bridge topologies.

The following figure shows the mechanism of phase shift:

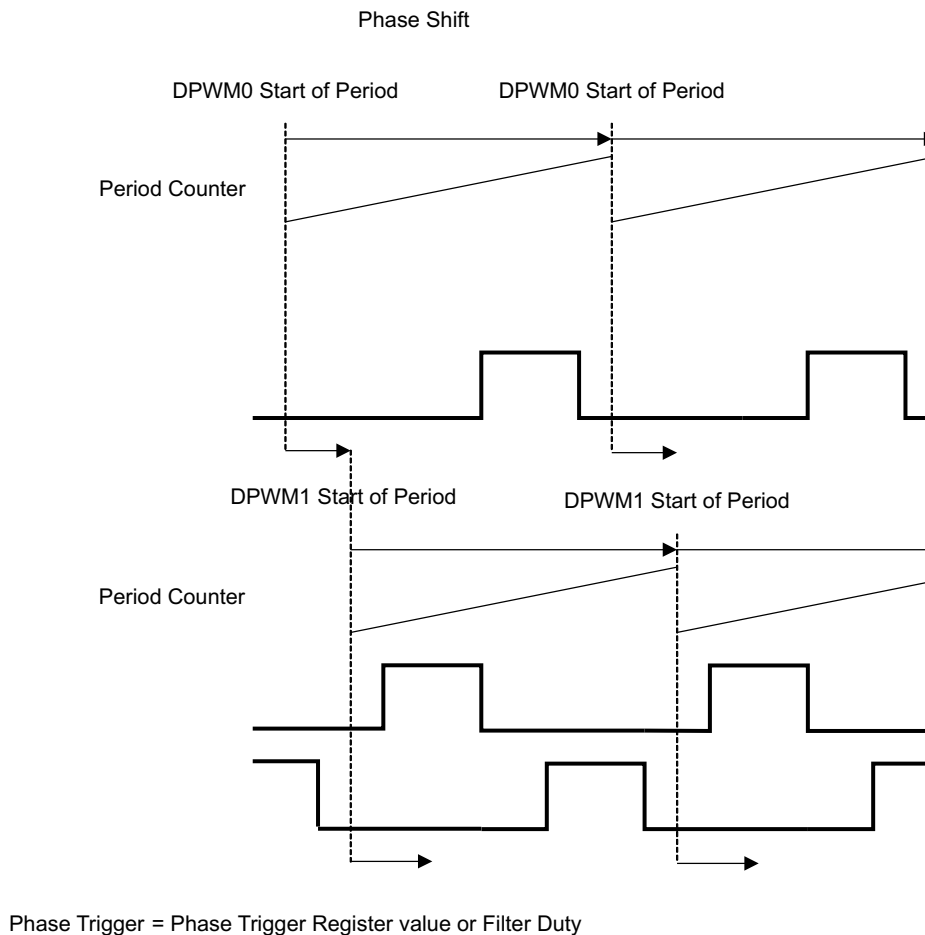

**Figure 40. Phase Shifting**

## 9.5 Register Maps

### 9.5.1 CPU Memory Map And Interrupts

When the device comes out of power-on-reset, the data memories are mapped to the processor as follows:

#### 9.5.1.1 Memory Map (After Reset Operation)

ADDRESS	SIZE (BYTES)	MODULE
0x0000_0000 – 0x0003_FFFF In 32 repeated blocks of 8 k each	32 X 8 k	Boot ROM
0x0004_0000 – 0x0004_7FFF	32 k	Program Flash 0
0x0004_8000 – 0x0004_FFFF	32 k	Program Flash 1
0x0005_0000_0x0005_7FFF	32 k	Program Flash 2
0x0005_0000_0x0005_7FFF	32 k	Program Flash 3
0x0006_9800 – 0x0006_9FFF	2 k	Data Flash
0x0006_A000 – 0x0006_BFFF	8 k	Data RAM

#### 9.5.1.2 Memory Map (Normal Operation)

Just before the boot ROM program gives control to flash program, the ROM configures the memory as follows:

ADDRESS	SIZE (BYTES)	MODULE
0x0002_0000 – 0x0002_1FFF	8 k	Boot ROM
0x0000_0000 – 0x0000_07FFF	32 k	Program Flash 0 (or 2)
0x0000_8000 – 0x0000_0FFFF	32 k	Program Flash 1 (or 3)
0x0001_8000 - 0x0001_07FFF	32 k	Program Flash 2 (or 0)
0x0001_8000 - 0x0001_FFF	32 k	Program Flash 3 (or 1)
0x0006_9800 – 0x0006_9FFF	2 k	Data Flash
0x0006_A000 – 0x0006_BFFF	8 k	Data RAM

#### 9.5.1.3 Memory Map (System And Peripherals Blocks)

ADDRESS	SIZE	MODULE
0x0012_0000 - 0x0012_00FF	256	Loop Mux
0x0013_0000 - 0x0013_00FF	256	Fault Mux
0x0014_0000 - 0x0014_00FF	256	ADC
0x0015_0000 - 0x0015_00FF	256	DPWM 3
0x0016_0000 - 0x0016_00FF	256	Filter 2
0x0017_0000 - 0x0017_00FF	256	DPWM 2
0x0018_0000 - 0x0018_00FF	256	Front End/Ramp Interface 2
0x0019_0000 - 0x0019_00FF	256	Filter 1
0x001A_0000 - 0x001A_00FF	256	DPWM 1
0x001B_0000 – 0x001B_00FF	256	Front End/Ramp Interface 1
0x001C_0000 - 0x001C_00FF	256	Filter 0
0x001D_0000 - 0x001D_00FF	256	DPWM 0
0x001E_0000 - 0x001E_00FF	256	Front End/Ramp Interface 0
0xFFFF7_E400 - 0xFFFF7_E4FF	256	RTC
0xFFFF7_E800-0xFFFF7_E8FF	256	SPI
0xFFFF7_EC00 - 0xFFFF7_ECFF	256	UART 0
0xFFFF7_ED00 - 0xFFFF7_EDFF	256	UART 1
0xFFFF7_F000 - 0xFFFF7_F0FF	256	Miscellaneous Analog Control
0xFFFF7_F600 - 0xFFFF7_F6FF	256	PMBus/I <sup>2</sup> C Interface (1)

ADDRESS	SIZE	MODULE
0xFFFF7_F700 - 0xFFFF7_F7FF	256	PMBus/I <sup>2</sup> C Interface (2)
0xFFFF7_FA00 - 0xFFFF7_FAFF	256	GIO
0xFFFF7_FD00 - 0xFFFF7_FDFF	256	Timer
0xFFFFF_FD00 - 0xFFFFF_FDFF	256	MMC
0xFFFFF_FE00 - 0xFFFFF_FEFF	256	DEC
0xFFFFF_FF20 - 0xFFFFF_FF37	23	CIM
0xFFFFF_FF00 - 0xFFFFF_FFEC	28	SYS

The registers and bit definitions inside the System and Peripheral blocks are detailed in the programmer's manuals.

### 9.5.2 Boot ROM

The device incorporates a 8 kB boot ROM. This boot ROM includes support for:

- Program download through the PMBus
- Device initialization
- Examining and modifying registers and memory
- Verifying and executing program flash automatically
- Jumping to a customer defined boot program
- Checksum evaluation to support using the program flash as a single 64 kB block or as 2-32 kB blocks.

The Boot ROM is entered automatically on device reset. It initializes the device and then performs checksums on the program flash. If the first 2 kB of program FLASH 0 has a valid checksum, the program branches to location 0 in Program FLASH 0. This permits the use of a custom boot program. If the first checksum fails, it performs some additional checksum calculations to determine where the valid program is located. This permits full automated program memory checking, when there is no need for a custom boot program. The complete decision tree is located in [Pseudo Code for ROM](#). Additionally, the part can support two separate programs in block 0 and block 1 through a custom boot-flash routine.

If none of the checksums are valid, the Boot ROM stays in control, and accepts commands via the PMBus interface. These functions can be used to read and write to all memory locations in the device. Typically they are at address 11 and are used to download a program to Program Flash, and to command its execution.

### 9.5.2.1 Pseudo Code for ROM

```
-> If PFLASH[0], location 0 = 0xEA
    -> If PFLASH[0] 2K/32K checksum is valid ==> Execute PFLASH[0]
    -> Else,
        -> If PFLASH[0-1] 64K checksum is valid ==> Execute PFLASH[0]
        -> If PFLASH[0-3] 128K checksum is valid ==> Execute PFLASH[0]
        -> If PFLASH[2], location 0 = 0xEA
            -> If PFLASH[2], location 0 = 0xEA
    -> Else If PFLASH[2], location 0 = 0xEA
        -> PFLASH[2-3] 64K checksum is valid ==> Execute PFLASH[2]
    -> Else
        -> Stay in ROM mode
```

### 9.5.3 Customer Boot Program

As described above, it is possible to generate a user boot program using 2 kB or more of the Program Flash. This can support things which the Boot ROM does not support, including:

- Program download via UART – useful especially for applications where the UCD3138128A is isolated from the host (that is, PFC)
- Encrypted download – useful for code security in field updates.
- PMBus download at different addresses
- Different command formats

### 9.5.4 Flash Management

The device offers a variety of features providing for easy prototyping and easy flash programming. At the same time, high levels of security are possible for production code, even with field updates. Standard firmware will be provided for storing multiple copies of system parameters in data flash. This minimizes the risk of losing information if data-flash programming is interrupted.

## 10 Applications and Implementation

### NOTE

Information in the following applications sections is not part of the TI component specification, and TI does not warrant its accuracy or completeness. TI's customers are responsible for determining suitability of components for their purposes. Customers should validate and test their design implementation to confirm system functionality.

### 10.1 Application Information

The UCD3138xA has an extensive set of fully-programmable, high-performance peripherals that make it suitable for a wide range of power supply applications. In order to make the part easier to use, TI has prepared an extensive set of materials to demonstrate the features of the device for several key applications. In each case the following items are available:

1. Full featured EVM hardware that demonstrates classic power supply functionality.
2. An EVM user guide that contains schematics, bill-of-materials, layout guidance and test data showcasing the performance and features of the device and the hardware.
3. A firmware programmers manual that provides a step-by-step walk through of the code.

**Table 7. Application Information**

APPLICATION	EVM DESCRIPTION
Phase shifted full bridge	This EVM demonstrates a PSFB DC-DC power converter with digital control using the UCD3138xA device. Control is implemented by using PCMC with slope compensation. This simplifies the hardware design by eliminating the need for a series blocking capacitors and providing the inherent input voltage feed-forward that comes from PCMC. The controller is located on a daughter card and requires firmware in order to operate. This firmware, along with the entire source code, is made available through TI. A free, custom function GUI is available to help the user experiment with the different hardware and software enabled features. The EVM accepts a DC input from 350 VDC to 400 VDC, and outputs a nominal 12 VDC with full load output power of 360 W, or full output current of 30 A.
LLC resonant converter	This EVM demonstrates an LLC resonant half-bridge DC-DC power converter with digital control using the UCD3138xA device. The controller is located on a daughter card and requires firmware in order to operate. This firmware, along with the entire source code, is made available through TI. A free, custom function GUI is available to help the user experiment with the different hardware and software enabled features. The EVM accepts a DC input from 350 VDC to 400 VDC, and outputs a nominal 12 VDC with full load output power of 340 W, or full output current of 29 A.

## 10.2 Typical Application

This section summarizes the PSFB EVM DC-DC power converter.

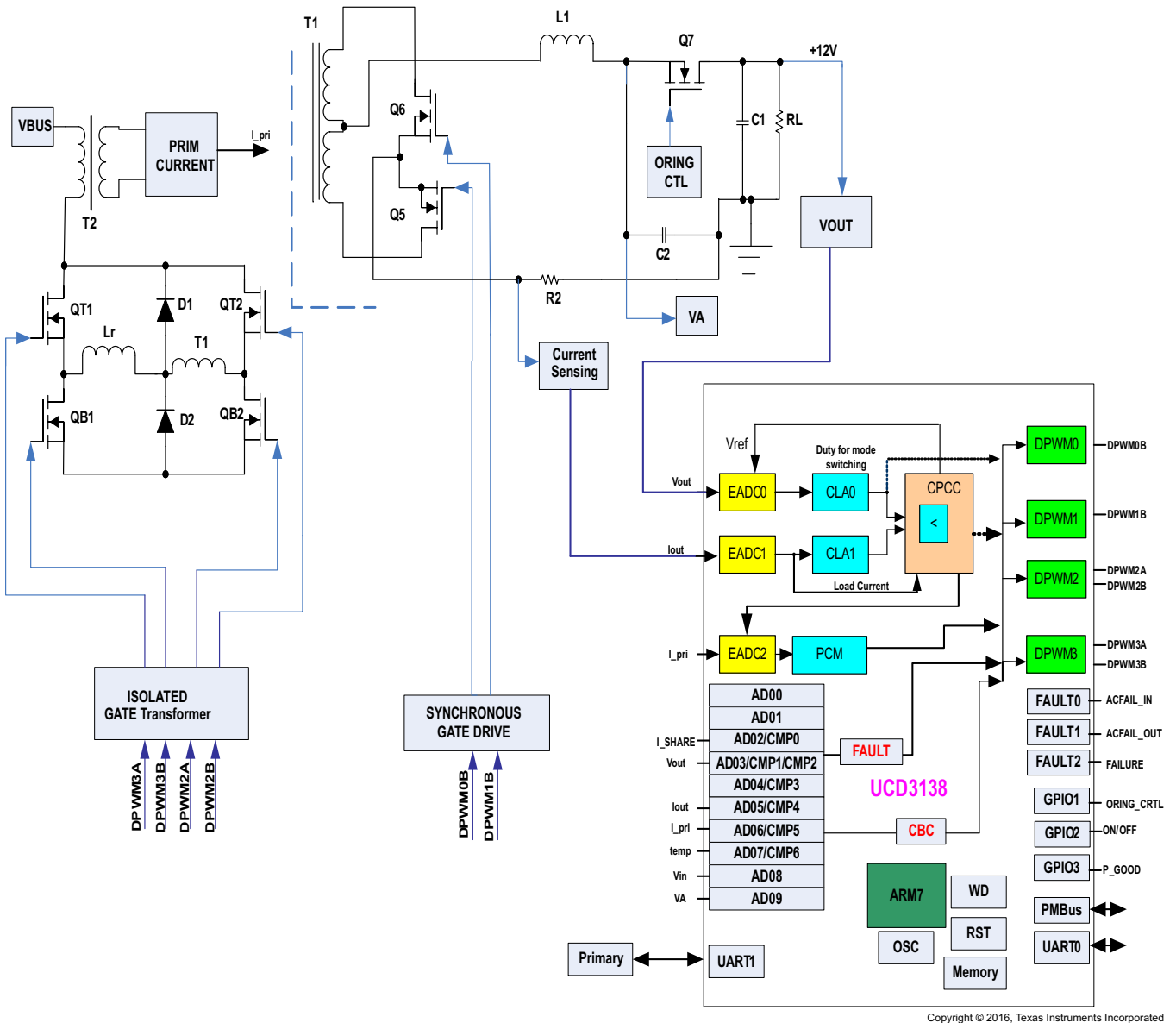

Figure 41. Phase-Shifted Full-Bridge

## Typical Application (continued)

### 10.2.1 Design Requirements

**Table 8. Input Characteristics**

PARAMETER		CONDITIONS	MIN	TYP	MAX	UNIT
<b>ALL SPECIFICATIONS at Vin=400V and 25°C AMBIENT UNLESS OTHERWISE NOTED.</b>						
V <sub>in</sub>	Input voltage range	Normal Operating	350	385	420	V
V <sub>inmax</sub>	Max input voltage	Continuous			420	V
I <sub>in</sub>	Input current	Vin=350V, Full Load		1.15		A
I <sub>stby</sub>	Input no load current	Output current is 0A		30		mA
V <sub>on</sub>	Under voltage lockout	V <sub>in</sub> Decreasing (input voltage is detected on secondary side)		340		V
V <sub>hys</sub>		V <sub>in</sub> Increasing		360		V

**Table 9. Output Characteristics**

PARAMETER		CONDITIONS	MIN	TYP	MAX	UNIT
<b>ALL SPECIFICATIONS at Vin=400V and 25°C AMBIENT UNLESS OTHERWISE NOTED.</b>						
V <sub>O</sub>	Output voltage setpoint	No load on outputs		12		V
Reg <sub>line</sub>	Line regulation	All outputs; 360 ≤ V <sub>in</sub> ≤ 420; I <sub>O</sub> = I <sub>Omax</sub>			0.5	%
Reg <sub>load</sub>	Load regulation	All outputs; 0 ≤ I <sub>O</sub> ≤ I <sub>Omax</sub> ; V <sub>in</sub> = 400 V			1	%
V <sub>n</sub>	Ripple and noise <sup>(1)</sup>	5Hz to 20 MHz		100		mVpp
I <sub>O</sub>	Output current		0		30	A
η	Efficiency at phase-shift mode	V <sub>O</sub> = 12 V, I <sub>O</sub> = 15 A		93%		
η	Efficiency at PWM ZVS mode	V <sub>O</sub> = 12 V, I <sub>O</sub> = 15 A		93%		
η	Efficiency at hard switching mode	V <sub>O</sub> = 12 V, I <sub>O</sub> = 15 A		90%		
V <sub>adj</sub>	Output adjust range		11.4		12.6	V
V <sub>tr</sub>	Transient response overshoot/undershoot	50% Load Step at 1AμS, min load at 2A		±0.36		V
t <sub>settling</sub>	Transient response settling time			100		μS
t <sub>start</sub>	Output rise time	10% to 90% of V <sub>out</sub>		50		mS
	Overshoot	At Startup			2	%
f <sub>s</sub>	Switching frequency	Over V <sub>in</sub> and I <sub>O</sub> ranges		150		kHz
I <sub>share</sub>	Current sharing accuracy	50% - full load		±5		%
φ	Loop phase margin	10% - Full load		45		degree
G	Loop gain margin	10% - Full load		10		dB

(1) Ripple and noise are measured with 10μF Tantalum capacitor and 0.1μF ceramic capacitor across output.

### 10.2.2 Detailed Design Procedure

#### 10.2.2.1 PCMC (Peak Current Mode Control) PSFB (Phase Shifted Full Bridge) Hardware Configuration Overview

The hardware configuration of the UCD3138xA PCMC PSFB converter contains two critical elements that are highlighted in the subsequent sections.

- DPWM initialization - This section will highlight the key register settings and considerations necessary for the UCD3138xA to generate the correct MOSFET waveforms for this topology. This maintains the proper phase relationship between the MOSFETs and synchronous rectifiers as well as the proper set up required to function correctly with PCMC.
- PCMC initialization - This section will discuss the register settings and hardware considerations necessary to modulate the DPWM pins with PCMC and internal slope compensation.

10.2.2.2 DPWM Initialization for PSFB

The UCD3138xA DPWM peripheral provides flexibility for a wide range of topologies. The PSFB configuration utilizes the Intra-Mux and Edge Generation Modules of the DPWM. For a diagram showing these modules, see the UCD3138xA Digital Power Peripherals Manual.

Here is a schematic of the power stage of the PSFB:

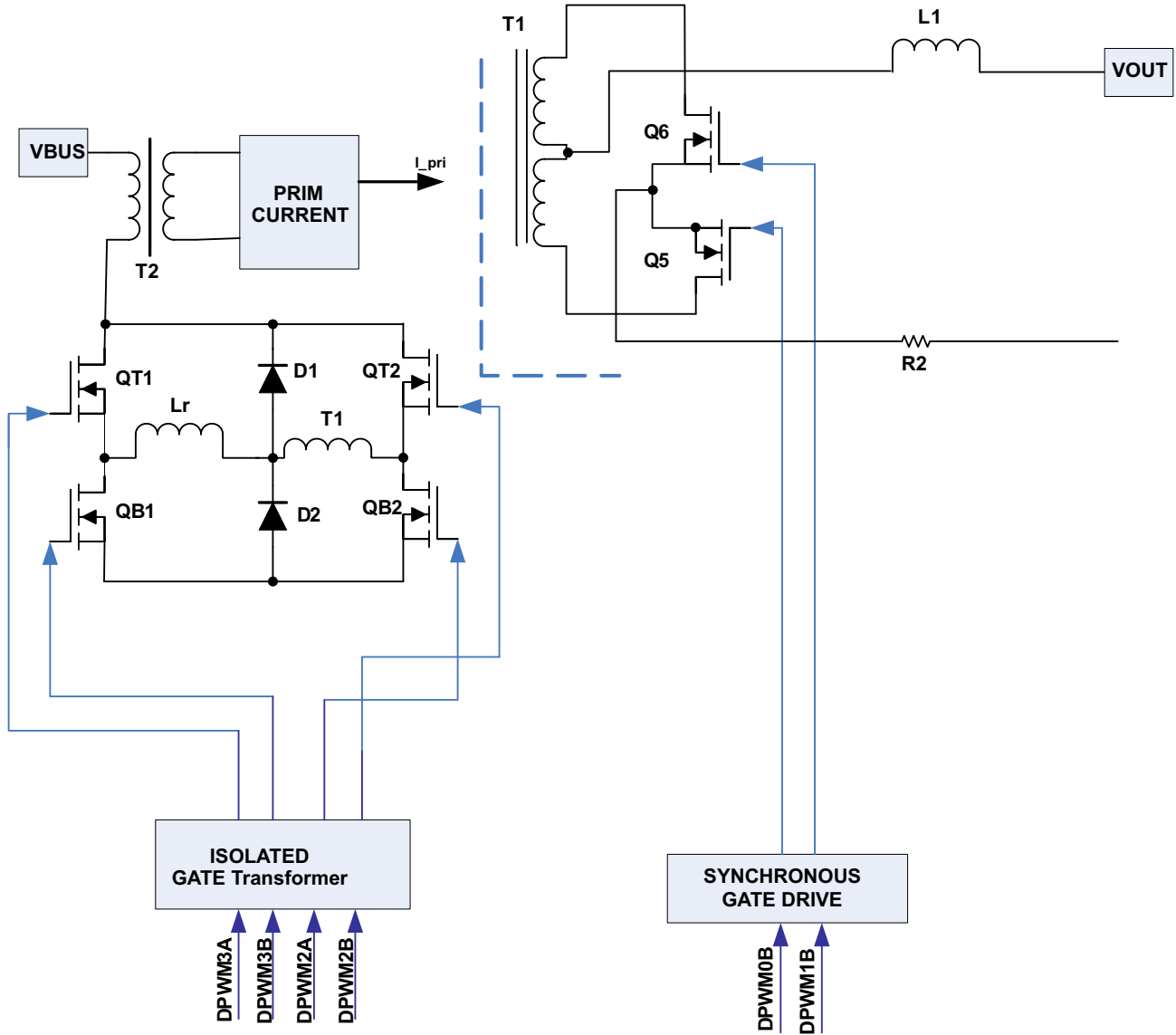

Copyright © 2016, Texas Instruments Incorporated

Figure 42. Schematic – PSFB Power Stage

Here is an overview of the key PSFB signals:

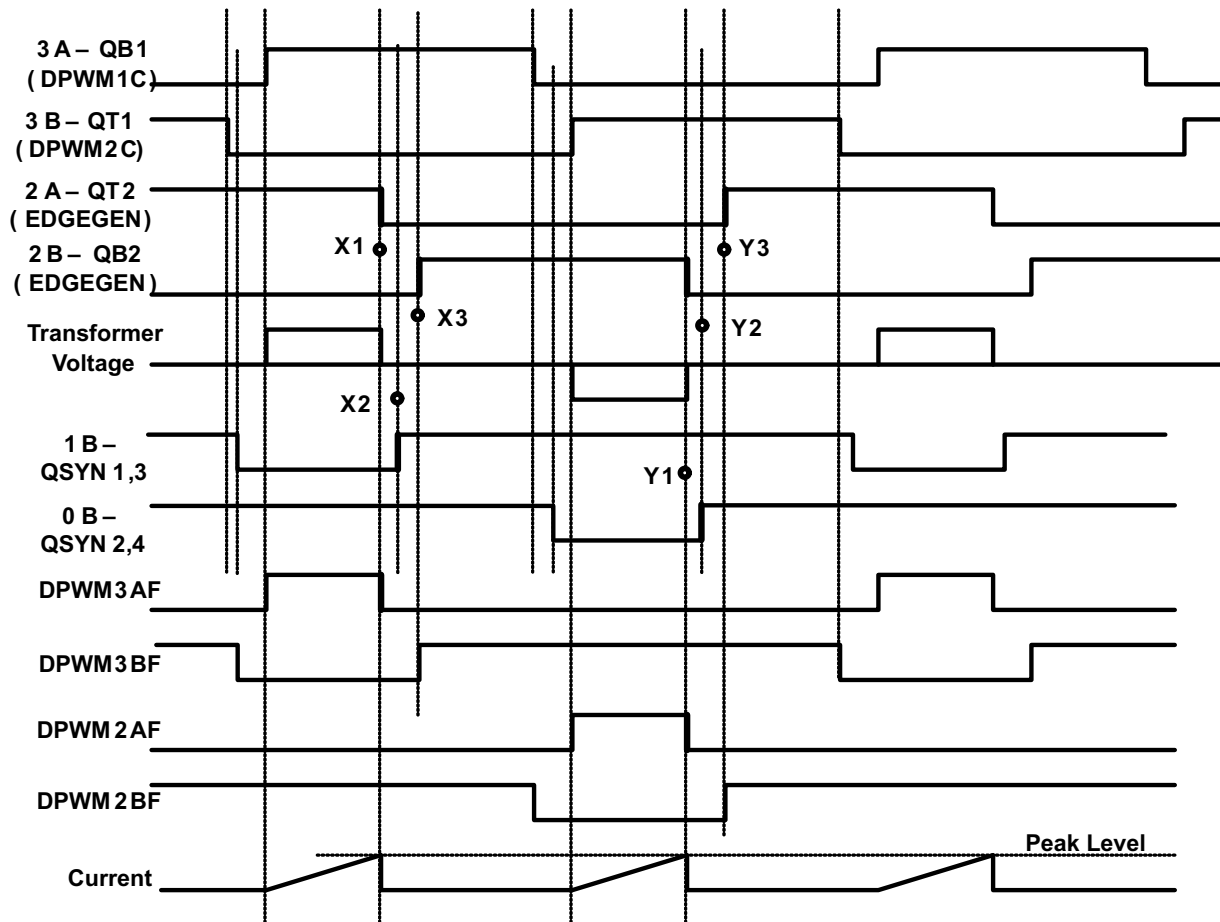

X1, X2, X3 and Y1, Y2, Y3 are sets of moving edges  
All other edges are fixed.

**Figure 43. Key PSFB Signals**

### 10.2.2.3 DPWM Synchronization

DPWM1 is synchronized to DPWM0, DPWM2 is synchronized to DPWM1, and DPWM3 is synchronized to DPWM2,  $\frac{1}{2}$  period out of phase using these commands:

```
Dpwm1Regs.DPWMCTRL0.bit.MSYNC_SLAVE_EN = 1; //configured to slave
Dpwm2Regs.DPWMCTRL0.bit.MSYNC_SLAVE_EN = 1; //configured to slave
Dpwm3Regs.DPWMCTRL0.bit.MSYNC_SLAVE_EN = 1; //configured to slave
```

```
Dpwm0Regs.DPWMPHASETRIG.all = PWM_SLAVESYNC;
Dpwm1Regs.DPWMPHASETRIG.all = PWM_SLAVESYNC;
Dpwm2Regs.DPWMPHASETRIG.all = PWM_SLAVESYNC;
```

```
LoopMuxRegs.DPMMUX.bit.DPWM1_SYNC_SEL = 0; // Slave to dpwm-0
LoopMuxRegs.DPMMUX.bit.DPWM2_SYNC_SEL = 1; // Slave to dpwm-1
LoopMuxRegs.DPMMUX.bit.DPWM3_SYNC_SEL = 2; // Slave to dpwm-2
```

If the event registers on the DPWMs are the same, the two pairs of signals will be symmetrical. All code examples are taken from the PSFB EVM code, unless otherwise stated.

10.2.2.4 Fixed Signals to Bridge

The two top signals in the above drawing have fixed timing. The DPWM1CF and DPWM2CF signals are used for these pins. DPWMCxF refers to the signal coming out of the fault module of DPWMx, as shown in Figure 44.

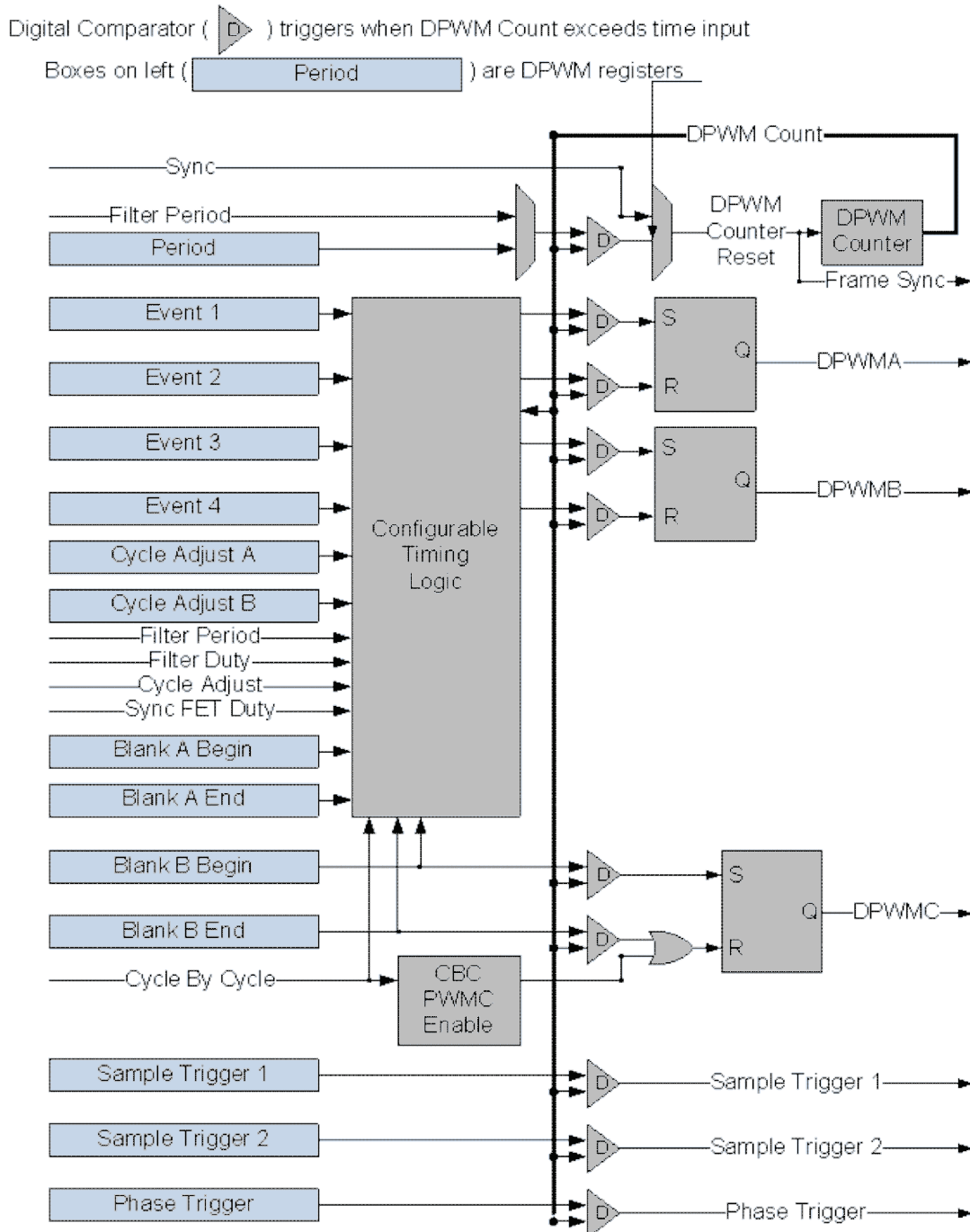

Figure 44. Fixed Signals to Bridge

These signals are actually routed to pins DPWM3A and 3B using the Intra Mux with these statements:

```
Dpwm3Regs.DPWMCTRL0.bit.PWM_A_INTRA_MUX = 7; // Send DPWM1C
Dpwm3Regs.DPWMCTRL0.bit.PWM_B_INTRA_MUX = 8; // Send DPWM2C
```

Since these signals are really being used as events in the timer, the #defines are called EV5 and EV6. Here are the statements which initialize them:

```
// Setup waveform for DPWM-C (re-using blanking B regs)
Dpwm2Regs.DPWMBLKBBEG.all = PWM2_EV5 + (4 x 16);
Dpwm2Regs.DPWMBLKBEND.all = PWM2_EV6;
```

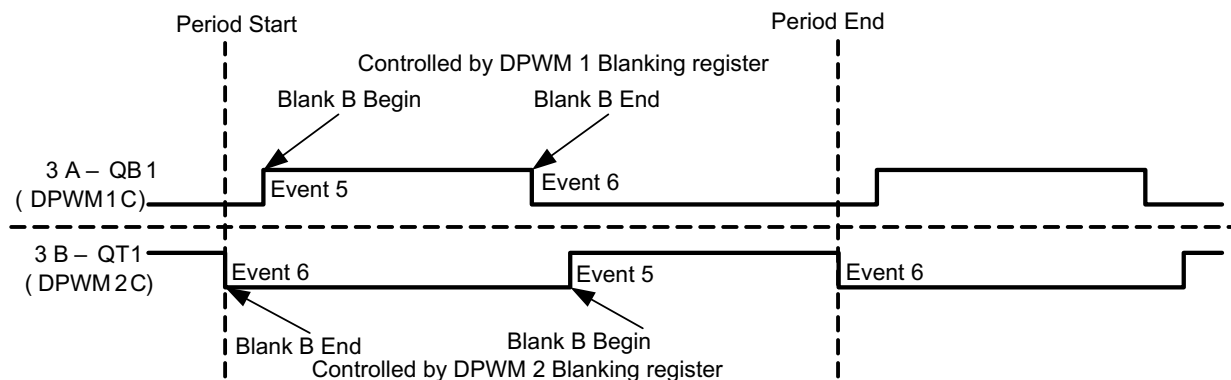

**Figure 45. Blank B Timing Information**

The statements for DPWM1 are the same. Remember that DPWMC reuses the Blank B registers for timing information.

### 10.2.2.5 Dynamic Signals to Bridge

DPWM0 and 1 are set at normal mode. PCMC triggering signal (fault) chops DPWM0A and 1A cycle by cycle. The corresponding DPWM0B and 1B are used for synchronous rectifier MOSFET control. The same PCMC triggering signal is applied to DPWM2 and DPWM3. Both of these are set to normal mode as well. DPWM2 and 3 are chopped and their edges are used to generate the next two dynamic signals to the bridge. They are generated using the Edge Generator Module in DPWM2. The Edge Generator sources are DPWM2 and DPWM3. The edges used are:

- DPWM2A turned on by a rising edge on DPWM2BF
- DPWM2A turned off by a falling edge on DPWM3AF
- DPWM2B turned on by a rising edge on DPWM3BF
- DPWM2B turned off by a falling edge on DPWM2AF

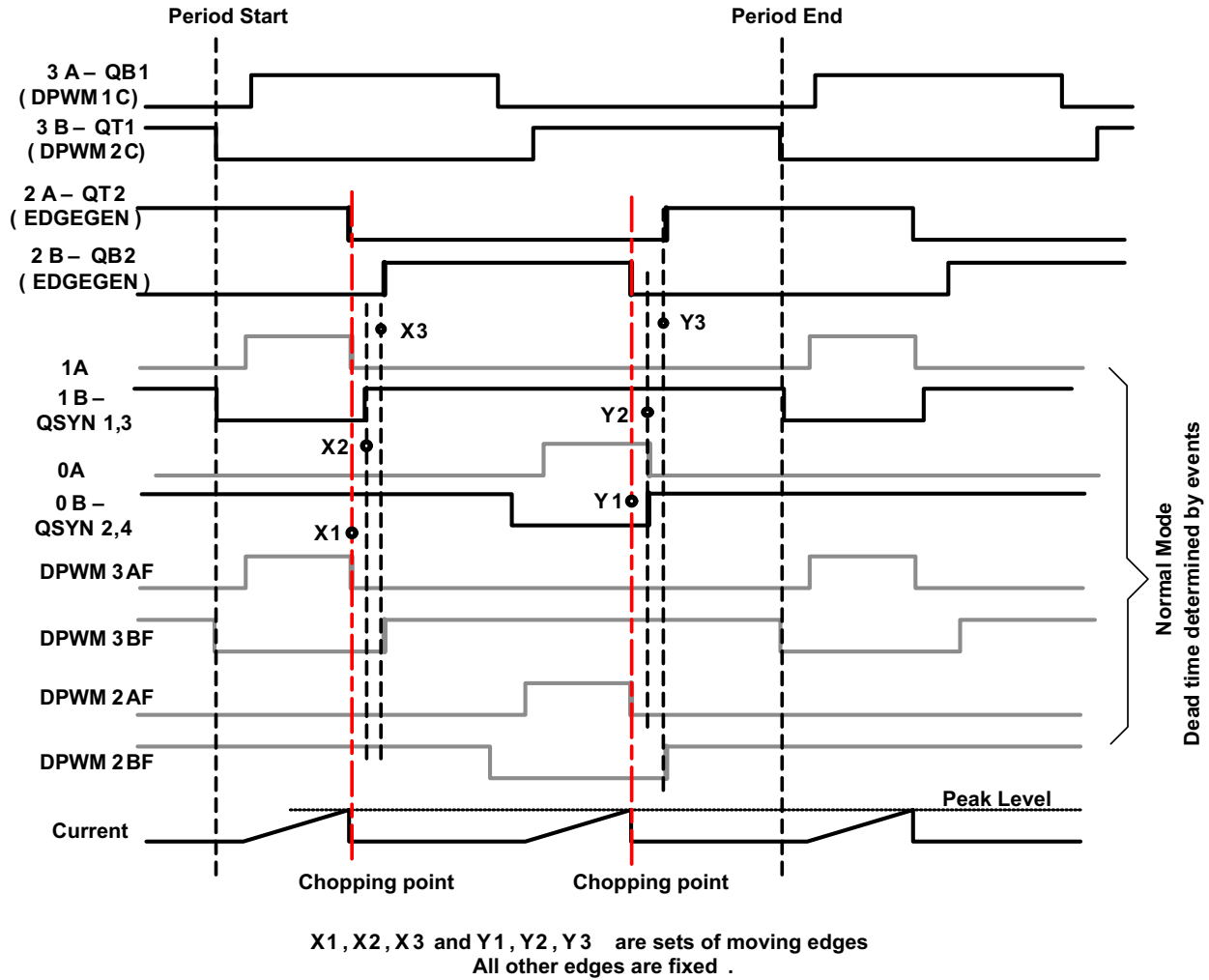

**Figure 46. Dynamic Signals to Bridge**

The Edge Generator is configured with these statements:

```
Dpwm2Regs.DPWMEDGEGEN.bit.A_ON_EDGE = 2;
Dpwm2Regs.DPWMEDGEGEN.bit.A_OFF_EDGE = 5;
Dpwm2Regs.DPWMEDGEGEN.bit.B_ON_EDGE = 6;
Dpwm2Regs.DPWMEDGEGEN.bit.B_OFF_EDGE = 1;

Dpwm2Regs.DPWMCTRL0.bit.PWM_A_INTRA_MUX = 1; // EDGEGEN-A out the A output
Dpwm2Regs.DPWMCTRL0.bit.PWM_B_INTRA_MUX = 1; // EDGEGEN-B out the B output

Dpwm2Regs.DPWMEDGEGEN.bit.EDGE_EN = 1;
```

The EDGE\_EN bits are set for all 4 DPWMs. This is done to ensure that all signals have the same timing delay through the DPWM.

The final 6 gate signals are shown in [Figure 47](#).

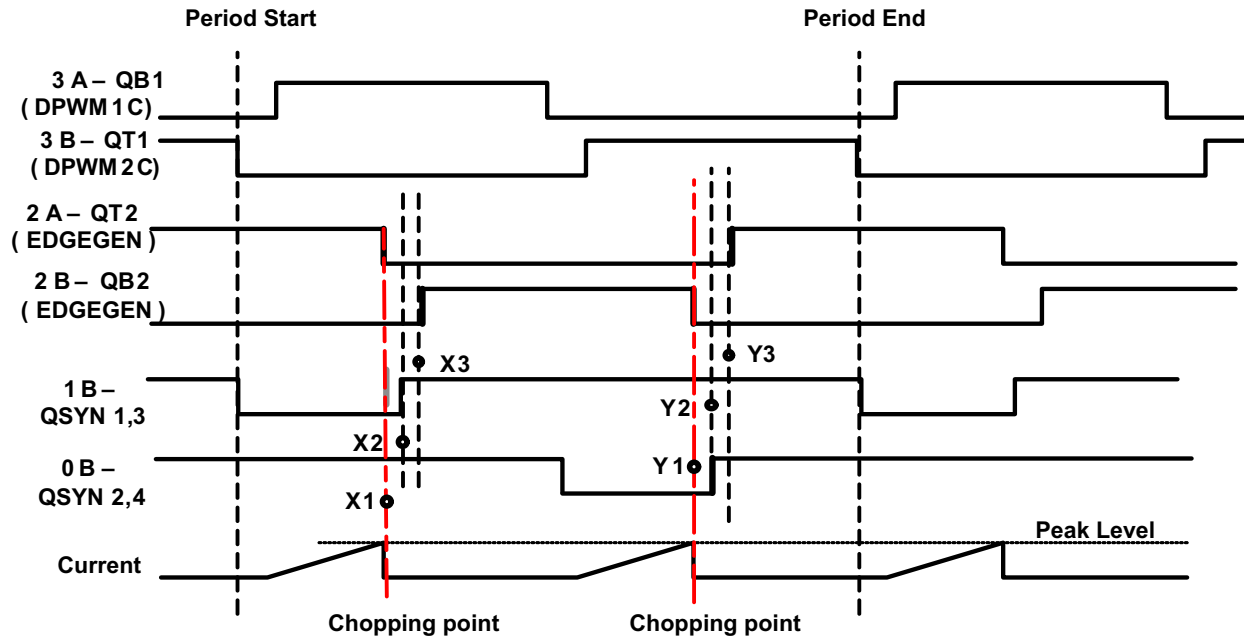

**Figure 47. Final 6 Gate Signals**

Note how the falling edge of DPWM2AF aligns with the X1 edge, and how the rising edge of DPWM2BF aligns with the X3 edge. The falling edges on DPWM2AF and DPWM3AF are caused by the peak detection logic. This is fed through the Cycle By Cycle logic. The Cycle By Cycle logic also has a special feature to control the rising edges of DPWM2BF (X1 and X3) and DPWM3BF (Y1 and Y3). It uses the value of Event3 – Event2 to control the time between the edges. The same feature is used with DPWM0 and DPWM1 to control the X2 and Y2 signals. Using the other 2 DPWMs permits these signals to have a different dead time.

The same setup can be used for voltage mode control. In this case, the Filter output sets the timing of the falling edge on DPWMxAF.

All DPWMs are configured in Normal mode, with CBC enabled. If external slope compensation is used, DPWM1A and DPWM1B are used to reset the external compensator at the beginning of each half cycle. If no PCMC event occurs, the values of Events 2 and 3 determine the locations of the edges, just as in open loop mode.

### 10.2.3 System Initialization for PCM

PCM (Peak Current Mode) is a specialized configuration for the UCD3138xA which involves several peripherals. This section describes how it works across the peripherals.

#### 10.2.3.1 Use of Front Ends and Filters in PSFB

All three front ends are used in PSFB. The same signals are used in the same places for both PCMC and voltage mode. The same hardware can be used for both control modes, with the mode determined by which firmware is loaded into the device. FE0 and FE1 are used with their associated filters, but Filter 2 is not used at all.

- FE0 – Vout – voltage loop
- FE1 – Iout – current loop
- FE2 – I<sub>pri</sub> – PCM

In PCMC mode, FE2 is used for PCMC, and the voltage loop is normally used to provide the start point for the compensation ramp. If the CPCC firmware detects a need for constant current mode, it switches to the current loop for the start point.

### 10.2.3.2 Peak Current Detection

Peak current detection involves all the major modules of the DPPs, the Front End, Filter, Loop Mux, Fault Mux and the DPWMs. A drawing of the major elements is shown in Figure 48.

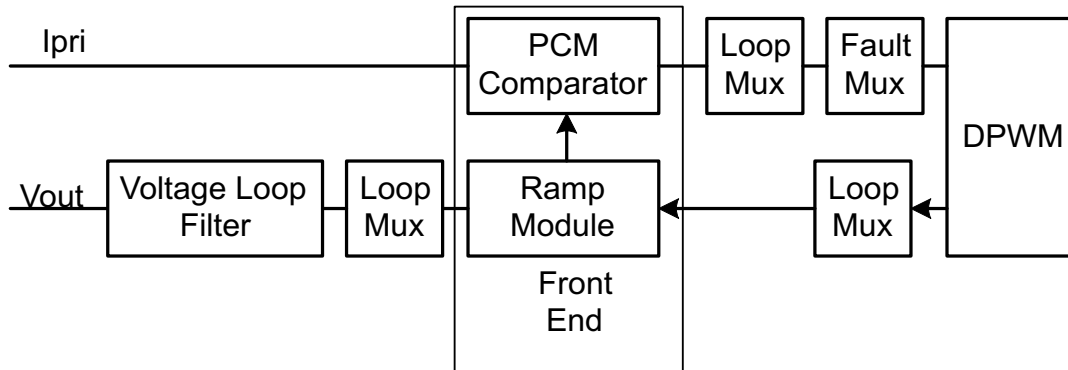

Figure 48. Peak Current Detection Function

All signals without arrows flow from left to right. The voltage loop is used to select a peak current level. This level is fed to the Ramp module to generate a compensation ramp. The compensation ramp is compared to the primary current by the PCMC comparator in the Front End. When the ramp value is greater than the primary current, the APCMC signal is sent to the DPWM, causing the events described in the previous sections.

The DPWM frame start and output pin signals can be used to trigger the Ramp Module. In this case, unlike in the case of other ramp module functions, each DPWM frame triggers the start of the ramp. The ramp steps every 32 ns.

The Filter is configured normally, there is no real difference for PCMC. The PCM\_FILTER\_SEL bits in the LoopMux.PCMCTRL register are used to select which filter is connected to the ramp module:

```
LoopMuxRegs.APCMCTRL.bit.PCM_FILTER_SEL = 0; //select filter0
```

With Firmware Constant Power/Constant current, Filter 1 and Front End 1 are used as a current control loop, with the EADC DAC set to high current. If the voltage loop value becomes higher than the current loop value, then Filter 1 is used to control the PCM ramp start value:

```
LoopMuxRegs.APCMCTRL.bit.PCM_FILTER_SEL = 1;
//select filter1 for slope compensation source
```

In the ramp module, there are 2 bitfields in the RAMPCTRL register which must be configured. The PCM\_START\_SEL must be set to a 1 to enable the Filter to be used as a ramp start source. The RAMP\_EN bit must be set, of course.

The DAC\_STEP register sets the slope of the compensation ramp. The DAC value is in volts, of course, so it is necessary to calculate the slope after the current to voltage conversion. Here is the formula for converting from millivolts per microsecond to DACSTEP.

*m* = compensation slope in millivolts per microsecond

$ACSTEP = 335.5 \times M$

In C, this can be written:

```
#define COMPENSATION_SLOPE 150 //compensation slope in millivolts per microsecond
#define DACSTEP_COMP_VALUE ((int) (COMPENSATION_SLOPE*335.5) )
//value in DACSTEP for desired compensation slope
FeCtrl0Regs.DACSTEP.all = DACSTEP_COMP_VALUE;
```

It may also be necessary to set a ramp ending value in the RAMPDACEND register.

In addition, it is necessary to set the D2S\_COMP\_EN bit in the EADCCTRL register. This is for enabling the differential to single ended comparator function. The front end diagram leaves it out for simplicity, but the connection between the DAC and the EADC amplifier is actually differential. The PCMC comparator, however, is single ended. So a conversion is necessary as shown in Figure 49.

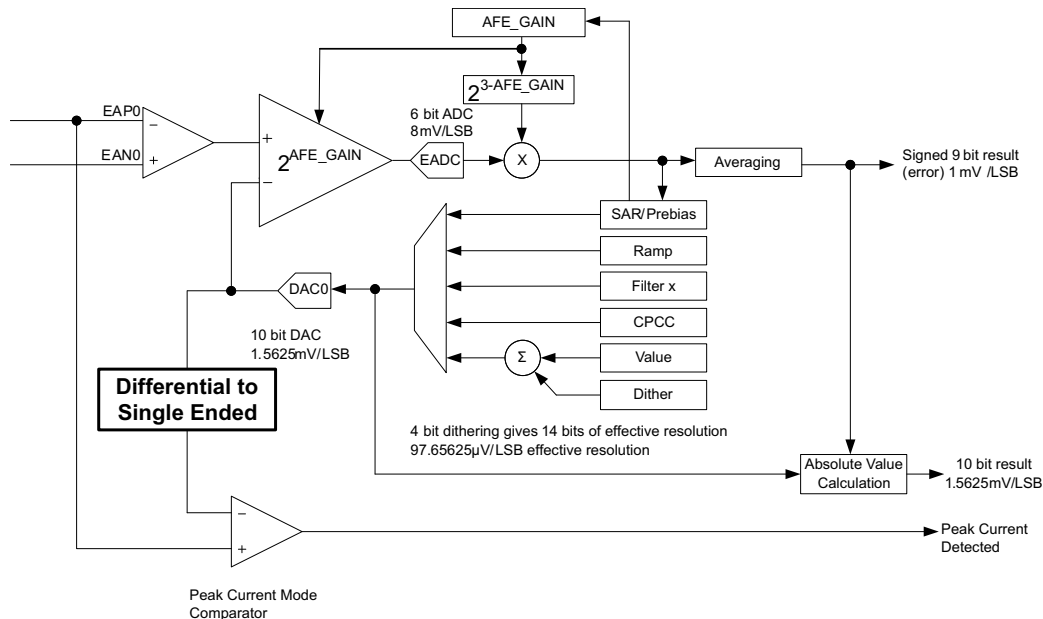

Figure 49. Differential to Single-Ended Comparator Function

The EADC\_MODE bit in EADCCTRL should be set to a 5 for peak current mode.

The peak current detection signal next goes to the Loop Mux. The Fault Mux has only 1 APCM input, but there are 3 front ends. So the PCM\_FE\_SEL bits in APCMCTRL must be used to select which front end is used:

```
LoopMuxRegs.APCMCTRL.bit.PCM_FE_SEL = 2; // use FE2 for PCM */
```

The PCM\_EN bit must also be set.

```
LoopMuxRegs.APCMCTRL.bit.PCM_EN = 1; // Enable PCM
```

Next the Fault Mux is used to enable the APCM bit to the CLIM/CBC signal to the DPWM. There are 4 DPWMxCLIM registers, one for each DPWM. The ANALOG\_PCM\_EN bit must be set in each one to connect the PCM detection signal to the CLIM/CBC signal on each DPWM. For the latest configuration information on all of these bits, consult the appropriate EVM firmware. To avoid errors, it is best to configure your hardware design using the same DPWMs, filters, and front ends for the same functions as the EVM.

DPWM timing is used to trigger the start of the ramp. This is selected by the FECTRLxMUX registers in the Loop Mux. DPWMx\_FRAME\_SYNC\_EN bits, when set, cause the ramp to be triggered at the start of the DPWM period.

### 10.2.3.3 Peak Current Mode (PCM)

There is one peak current mode control module in the device however any front end can be configured to use this module.

### 10.2.4 Application Curves

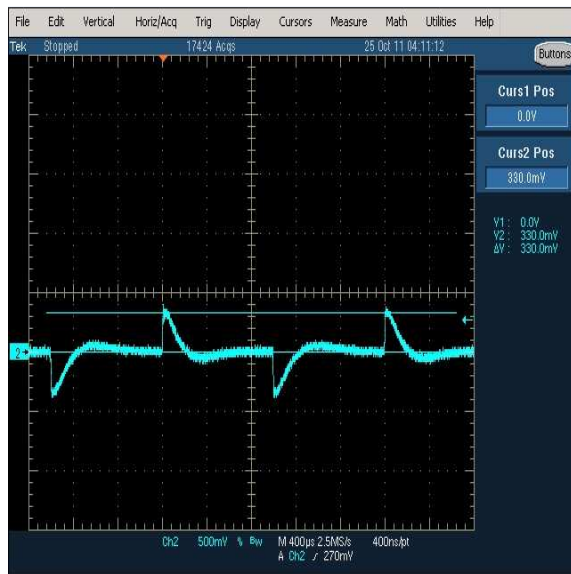

Figure 50. Load Transient

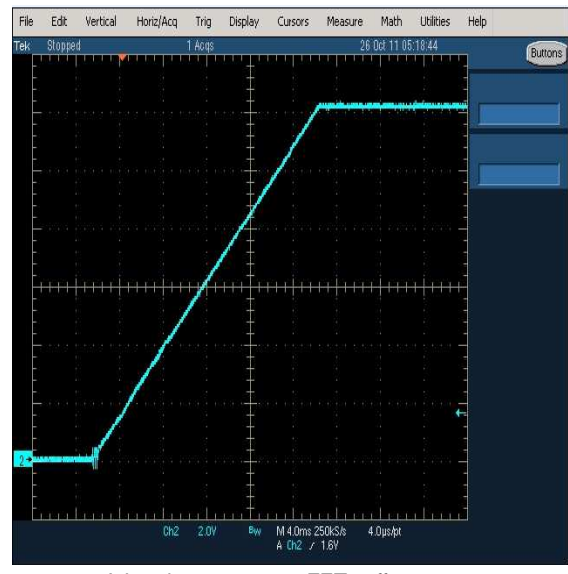

Figure 51. V<sub>OUT</sub> Soft Start

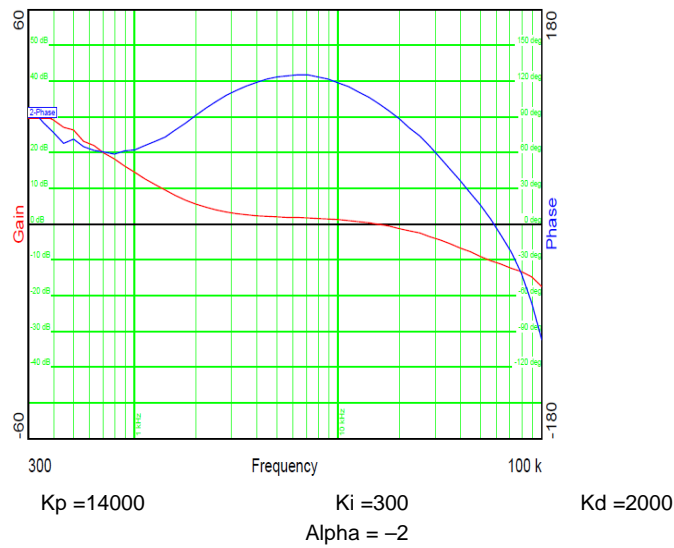

Figure 52. Bode Plot

## 11 Power Supply Recommendations

- Both 3.3 VD and 3.3 VA should have a local capacitor of at least 4.7- $\mu$ F in parallel with a 10-nF capacitor placed as close as possible to the device pins.
- BP18 should have a 1- $\mu$ F capacitor in parallel with a 10-nF capacitor to ground.

For detailed practical design guidelines, refer to ([SLUA779](#)).

## 12 Layout

### 12.1 Device Grounding and Layout Guidelines

- Single ground is recommended: SGND. A multilayer such as 4 layers board is recommended so that one solid SGND is dedicated for return current path, referred to the layout example.
- Apply multiple different capacitors for different frequency range on decoupling circuits. Each capacitor has different ESL, Capacitance and ESR, and they have different frequency response.
- Avoid long traces close to radiation components, and place them into an internal layer, and it is preferred to have grounding shield.
- Analog circuits and digital circuits should have separate return to ground; although with a single plane, still try to avoid mixing analog current and digital current.
- Do not use a ferrite bead or larger than 3- $\Omega$  resistor to connect between V33A and V33D.
- Both 3.3VD and 3.3VA should have local decoupling capacitors close to the device power pins, add vias to connect decoupling caps directly to SGND.
- Avoid negative current/negative voltage on all pins, so Schottky clamping diodes may be needed to limit the voltage; avoid more than 3.8 V or less than -0.3 V voltage spikes on all pins; add Schottky diodes on the pins which could have voltage spikes during surge test; be aware that a Schottky has relatively higher leakage current, which can affect the voltage sensing at high temperature.
- If V33 slew rate is less than 2.5 V/ms the RESET pin should have a 2.21-k $\Omega$  resistor between the reset pin and V33D and a 2.2- $\mu$ F capacitor from RESET to ground. For more details please refer to the [UCD3138 Family - Practical Design Guideline](#) This capacitor must be located close to the device RESET pin.
- If the XTAL\_IN (Pin 61) and XTAL\_OUT (Pin 62) are not used for external clock, tie them to 1.8 V (Pin BP18) through a 1-k $\Omega$  resistor respectively.
- Configure unused GPIO pins to be inputs or connect them to the ground (DGND or SGND); when an external pull-up resistor is used for GPIO, the pull-up resistor needs to be 1 k $\Omega$  or higher.

For detailed practical design guidelines, refer to ([UCD3138 Family - Practical Design Guideline](#)).

## 12.2 Layout Examples

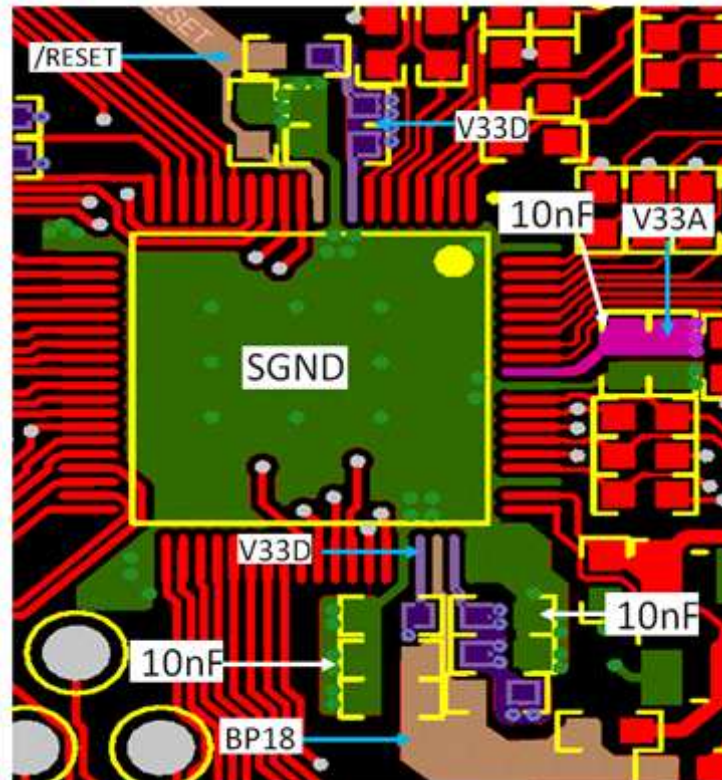

Figure 53. Layout Example for UCD3138128A Top Layer

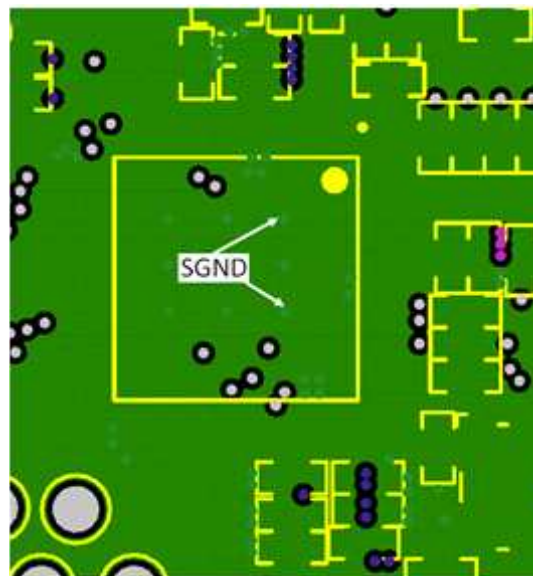

Figure 54. Layout Example for UCD3138128A Internal Ground Layer

## 13 Device and Documentation Support

### 13.1 Device Support

#### 13.1.1 Development Support

The application firmware for the UCD3138xA is developed on Texas Instruments Code Composer Studio (CCS) integrated development environment.

Device programming, real time debug and monitoring/configuration of key device parameters for certain power topologies are all available through Texas Instruments' FUSION\_DIGITAL\_POWER\_DESIGNER Graphical User Interface ([http://www.ti.com/tool/fusion\\_digital\\_power\\_designer](http://www.ti.com/tool/fusion_digital_power_designer)). The FUSION\_DIGITAL\_POWER\_DESIGNER software application uses the PMBus protocol to communicate with the device over a serial bus using an interface adaptor known as the USB-TO-GPIO, available as an EVM from Texas Instruments (<http://www.ti.com/tool/usb-to-gpio>). PMBUS-based real-time debug capability is available through the 'Memory Debugger' tool within the Device GUI module of the FUSION\_DIGITAL\_POWER\_DESIGNER GUI, which represents a powerful alternative over traditional JTAG-based approaches'.

The software application can also be used to program the devices, with a version of the tool known as FUSION\_MFR\_GUI optimized for manufacturing environments ([http://www.ti.com/tool/fusion\\_mfr\\_gui](http://www.ti.com/tool/fusion_mfr_gui)). The FUSION\_MFR\_GUI tool supports multiple devices on a board, and includes built-in logging and reporting capabilities.

### 13.2 Documentation Support

#### 13.2.1 Related Documentation

In terms of reference documentation, the following programmer's manuals are available offering detailed information regarding the application and usage of UCD3138xA digital controller:

1. UCD3138064A or UCD3138128A Programmer's Manual
2. UCD3138 Digital Power Peripheral Programmer's Manual Key Topics Covered in This Manual Include:
  - Digital Pulse Width Modulator (DPWM)
    - Modes of Operation (Normal/Multi/Phase-shift/Resonant etc)
    - Automatic Mode Switching
    - DPWMC, Edge Generation and Intra-Mux
  - Front End
    - Analog Front End
    - Error ADC or EADC
    - Front End DAC
    - Ramp Module
    - Successive Approximation Register Module
  - Filter
    - Filter Math
  - Loop Mux
    - Analog Peak Current Mode
    - Constant Power/Constant Current (CPCC)
    - Automatic Cycle Adjustment
  - Fault Mux
    - Analog Comparators
    - Digital Comparators
    - Fault Pin functions
    - DPWM Fault Action
    - Ideal Diode Emulation (IDE), DCM Detection
    - Oscillator Failure Detection
  - Register Map for all of the above peripherals in UCD3138A64 or UCD3138128

## Documentation Support (continued)

### 3. UCD3138 Monitoring and Communications Programmer's Manual

Key Topics Covered in This Manual Include:

- ADC12
  - Control, Conversion, Sequencing & Averaging
  - Digital Comparators
  - Temperature Sensor
  - PMBUS Addressing
  - Dual Sample and Hold
- Miscellaneous Analog Controls (Current Sharing, Brown-Out, Clock-Gating)
- PMBUS Interface
- General Purpose Input Output (GPIO)
- Timer Modules
- PMBus
- Register Map for all of the Above Peripherals in UCD3138A64

### 4. UCD3138 ARM and Digital System Programmer's Manual

Key topics covered in this manual include:

- Boot ROM and Boot Flash
  - BootROM Function
  - Memory Read/Write Functions
  - Checksum Functions
  - Flash Functions
  - Avoiding Program Flash Lock-Up
- ARM7 Architecture
  - Modes of Operation
  - Hardware/Software Interrupts
  - Instruction Set
  - Dual State Inter-working (Thumb 16-bit Mode/ARM 32-bit Mode)
- Memory and System Module
  - Address Decoder, DEC (Memory Mapping)
  - Memory Controller (MMC)
  - Central Interrupt Module
- Register Map for all of the above peripherals in UCD3138A64 or UCD3138128

### 5. FUSION\_DIGITAL\_POWER\_DESIGNER for UCD31XX Isolated Power Applications – User Guide

## Documentation Support (continued)

### 13.2.1.1 References

1. UCD3138064 Programmer's Manual (Literature Number: [SLUUAD8](#) )
2. UCD3138 Digital Power Peripherals Programmer's Manual (Literature Number:[SLUU995](#))
3. UCD3138 Monitoring & Communications Programmer's Manual (Literature Number:[SLUU996](#))
4. UCD3138 ARM and Digital System Programmer's Manual (Literature Number:[SLUU994](#))
5. FUSION\_DIGITAL\_POWER\_DESIGNER for Isolated Power Applications (Literature Number: [SLUA676](#))
6. Code Composer Studio Development Tools v3.3 – Getting Started Guide, (Literature Number: [SPRU509H](#))
7. ARM7TDMI-S Technical Reference Manual
8. System Management Bus (SMBus) Specification
9. PMBus™ Power System Management Protocol Specification
10. UCD3138128 Programmers Manual (Literature Number: [SLUUB54](#))
11. UCD3138 Family - Practical Design Guideline (Literature Number: [SLUA779](#))

In addition to the tools and documentation described above, for the most up to date information regarding evaluation modules, reference application firmware and application notes/design tips, please visit <http://www.ti.com/product/UCD3138A64>.

## 13.3 Receiving Notification of Documentation Updates

To receive notification of documentation updates, navigate to the device product folder on ti.com. In the upper right corner, click on *Alert me* to register and receive a weekly digest of any product information that has changed. For change details, review the revision history included in any revised document.

## 13.4 Trademarks

PMBus is a trademark of SMIF, Inc.

All other trademarks are the property of their respective owners.

## 13.5 Electrostatic Discharge Caution



These devices have limited built-in ESD protection. The leads should be shorted together or the device placed in conductive foam during storage or handling to prevent electrostatic damage to the MOS gates.

## 13.6 Glossary

[SLYZ022](#) — *TI Glossary*.

This glossary lists and explains terms, acronyms, and definitions.

## 14 Mechanical, Packaging, and Orderable Information

The following pages include mechanical, packaging, and orderable information. This information is the most current data available for the designated devices. This data is subject to change without notice and revision of this document. For browser-based versions of this data sheet, refer to the left-hand navigation.

**PACKAGING INFORMATION**

Orderable Device	Status (1)	Package Type	Package Drawing	Pins	Package Qty	Eco Plan (2)	Lead/Ball Finish (6)	MSL Peak Temp (3)	Op Temp (°C)	Device Marking (4/5)	Samples
UCD3138128APFC	ACTIVE	TQFP	PFC	80	96	Green (RoHS & no Sb/Br)	CU NIPDAU	Level-3-260C-168 HR	-40 to 125	UCD3138128A	<a href="#">Samples</a>
UCD3138128APFCR	ACTIVE	TQFP	PFC	80	1000	Green (RoHS & no Sb/Br)	CU NIPDAU	Level-3-260C-168 HR	-40 to 125	UCD3138128A	<a href="#">Samples</a>

(1) The marketing status values are defined as follows:

**ACTIVE:** Product device recommended for new designs.

**LIFEBUY:** TI has announced that the device will be discontinued, and a lifetime-buy period is in effect.

**NRND:** Not recommended for new designs. Device is in production to support existing customers, but TI does not recommend using this part in a new design.

**PREVIEW:** Device has been announced but is not in production. Samples may or may not be available.

**OBSELETE:** TI has discontinued the production of the device.

(2) Eco Plan - The planned eco-friendly classification: Pb-Free (RoHS), Pb-Free (RoHS Exempt), or Green (RoHS & no Sb/Br) - please check <http://www.ti.com/productcontent> for the latest availability information and additional product content details.

**TBD:** The Pb-Free/Green conversion plan has not been defined.

**Pb-Free (RoHS):** TI's terms "Lead-Free" or "Pb-Free" mean semiconductor products that are compatible with the current RoHS requirements for all 6 substances, including the requirement that lead not exceed 0.1% by weight in homogeneous materials. Where designed to be soldered at high temperatures, TI Pb-Free products are suitable for use in specified lead-free processes.

**Pb-Free (RoHS Exempt):** This component has a RoHS exemption for either 1) lead-based flip-chip solder bumps used between the die and package, or 2) lead-based die adhesive used between the die and leadframe. The component is otherwise considered Pb-Free (RoHS compatible) as defined above.

**Green (RoHS & no Sb/Br):** TI defines "Green" to mean Pb-Free (RoHS compatible), and free of Bromine (Br) and Antimony (Sb) based flame retardants (Br or Sb do not exceed 0.1% by weight in homogeneous material)

(3) MSL, Peak Temp. - The Moisture Sensitivity Level rating according to the JEDEC industry standard classifications, and peak solder temperature.

(4) There may be additional marking, which relates to the logo, the lot trace code information, or the environmental category on the device.

(5) Multiple Device Markings will be inside parentheses. Only one Device Marking contained in parentheses and separated by a "~" will appear on a device. If a line is indented then it is a continuation of the previous line and the two combined represent the entire Device Marking for that device.

(6) Lead/Ball Finish - Orderable Devices may have multiple material finish options. Finish options are separated by a vertical ruled line. Lead/Ball Finish values may wrap to two lines if the finish value exceeds the maximum column width.

**Important Information and Disclaimer:** The information provided on this page represents TI's knowledge and belief as of the date that it is provided. TI bases its knowledge and belief on information provided by third parties, and makes no representation or warranty as to the accuracy of such information. Efforts are underway to better integrate information from third parties. TI has taken and continues to take reasonable steps to provide representative and accurate information but may not have conducted destructive testing or chemical analysis on incoming materials and chemicals. TI and TI suppliers consider certain information to be proprietary, and thus CAS numbers and other limited information may not be available for release.

In no event shall TI's liability arising out of such information exceed the total purchase price of the TI part(s) at issue in this document sold by TI to Customer on an annual basis.

## TAPE AND REEL INFORMATION

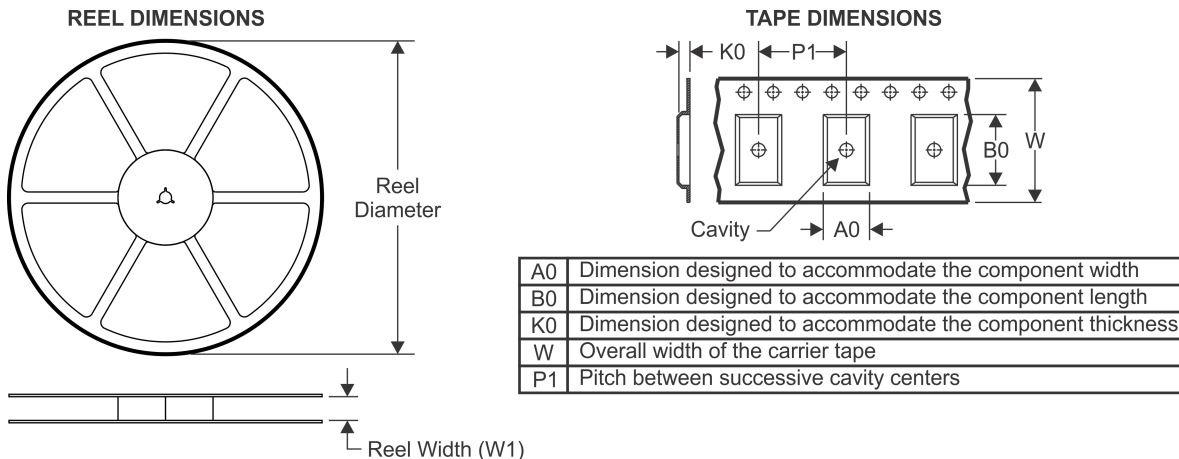

### QUADRANT ASSIGNMENTS FOR PIN 1 ORIENTATION IN TAPE

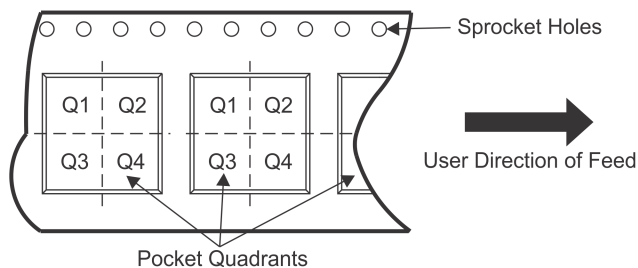

\*All dimensions are nominal

Device	Package Type	Package Drawing	Pins	SPQ	Reel Diameter (mm)	Reel Width W1 (mm)	A0 (mm)	B0 (mm)	K0 (mm)	P1 (mm)	W (mm)	Pin1 Quadrant
UCD3138128APFCR	TQFP	PFC	80	1000	330.0	24.4	15.0	15.0	1.5	20.0	24.0	Q2

**TAPE AND REEL BOX DIMENSIONS**

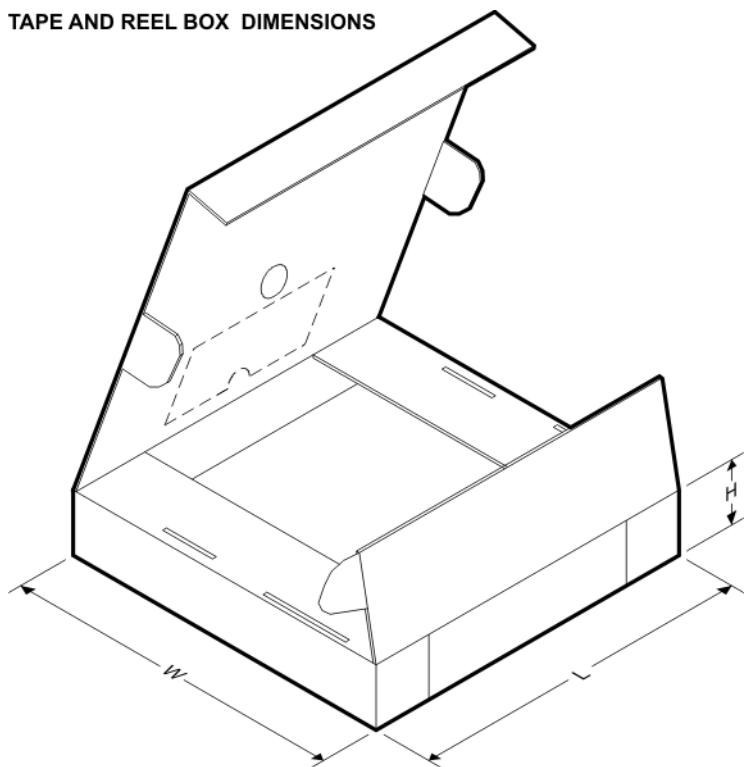

\*All dimensions are nominal

Device	Package Type	Package Drawing	Pins	SPQ	Length (mm)	Width (mm)	Height (mm)
UCD3138128APFCR	TQFP	PFC	80	1000	367.0	367.0	45.0

PFC (S-PQFP-G80)

PLASTIC QUAD FLATPACK

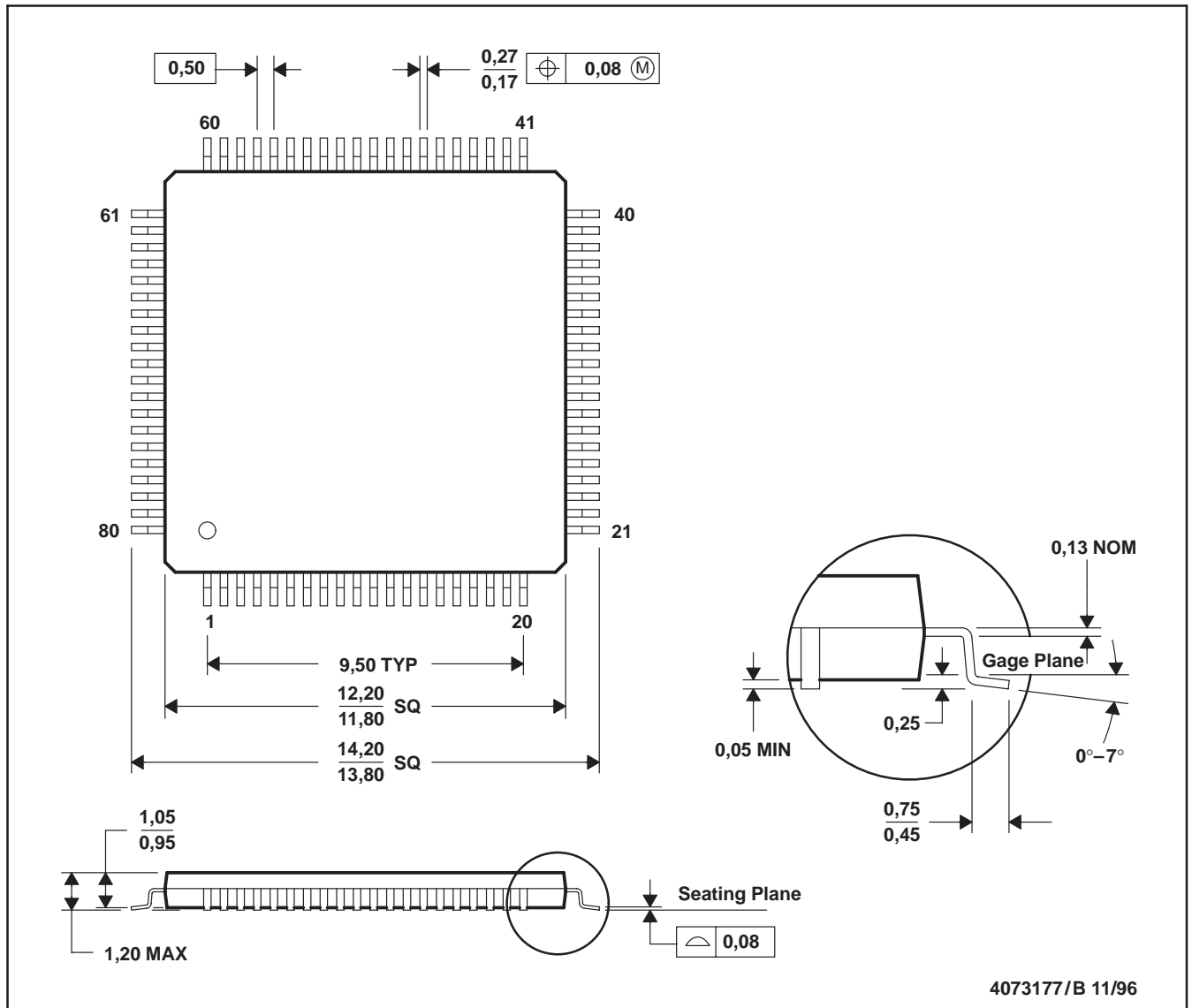

- NOTES: A. All linear dimensions are in millimeters.  
 B. This drawing is subject to change without notice.  
 C. Falls within JEDEC MS-026

## IMPORTANT NOTICE FOR TI DESIGN INFORMATION AND RESOURCES

Texas Instruments Incorporated ("TI") technical, application or other design advice, services or information, including, but not limited to, reference designs and materials relating to evaluation modules, (collectively, "TI Resources") are intended to assist designers who are developing applications that incorporate TI products; by downloading, accessing or using any particular TI Resource in any way, you (individually or, if you are acting on behalf of a company, your company) agree to use it solely for this purpose and subject to the terms of this Notice.

TI's provision of TI Resources does not expand or otherwise alter TI's applicable published warranties or warranty disclaimers for TI products, and no additional obligations or liabilities arise from TI providing such TI Resources. TI reserves the right to make corrections, enhancements, improvements and other changes to its TI Resources.

You understand and agree that you remain responsible for using your independent analysis, evaluation and judgment in designing your applications and that you have full and exclusive responsibility to assure the safety of your applications and compliance of your applications (and of all TI products used in or for your applications) with all applicable regulations, laws and other applicable requirements. You represent that, with respect to your applications, you have all the necessary expertise to create and implement safeguards that (1) anticipate dangerous consequences of failures, (2) monitor failures and their consequences, and (3) lessen the likelihood of failures that might cause harm and take appropriate actions. You agree that prior to using or distributing any applications that include TI products, you will thoroughly test such applications and the functionality of such TI products as used in such applications. TI has not conducted any testing other than that specifically described in the published documentation for a particular TI Resource.

You are authorized to use, copy and modify any individual TI Resource only in connection with the development of applications that include the TI product(s) identified in such TI Resource. NO OTHER LICENSE, EXPRESS OR IMPLIED, BY ESTOPPEL OR OTHERWISE TO ANY OTHER TI INTELLECTUAL PROPERTY RIGHT, AND NO LICENSE TO ANY TECHNOLOGY OR INTELLECTUAL PROPERTY RIGHT OF TI OR ANY THIRD PARTY IS GRANTED HEREIN, including but not limited to any patent right, copyright, mask work right, or other intellectual property right relating to any combination, machine, or process in which TI products or services are used. Information regarding or referencing third-party products or services does not constitute a license to use such products or services, or a warranty or endorsement thereof. Use of TI Resources may require a license from a third party under the patents or other intellectual property of the third party, or a license from TI under the patents or other intellectual property of TI.

TI RESOURCES ARE PROVIDED "AS IS" AND WITH ALL FAULTS. TI DISCLAIMS ALL OTHER WARRANTIES OR REPRESENTATIONS, EXPRESS OR IMPLIED, REGARDING TI RESOURCES OR USE THEREOF, INCLUDING BUT NOT LIMITED TO ACCURACY OR COMPLETENESS, TITLE, ANY EPIDEMIC FAILURE WARRANTY AND ANY IMPLIED WARRANTIES OF MERCHANTABILITY, FITNESS FOR A PARTICULAR PURPOSE, AND NON-INFRINGEMENT OF ANY THIRD PARTY INTELLECTUAL PROPERTY RIGHTS.

TI SHALL NOT BE LIABLE FOR AND SHALL NOT DEFEND OR INDEMNIFY YOU AGAINST ANY CLAIM, INCLUDING BUT NOT LIMITED TO ANY INFRINGEMENT CLAIM THAT RELATES TO OR IS BASED ON ANY COMBINATION OF PRODUCTS EVEN IF DESCRIBED IN TI RESOURCES OR OTHERWISE. IN NO EVENT SHALL TI BE LIABLE FOR ANY ACTUAL, DIRECT, SPECIAL, COLLATERAL, INDIRECT, PUNITIVE, INCIDENTAL, CONSEQUENTIAL OR EXEMPLARY DAMAGES IN CONNECTION WITH OR ARISING OUT OF TI RESOURCES OR USE THEREOF, AND REGARDLESS OF WHETHER TI HAS BEEN ADVISED OF THE POSSIBILITY OF SUCH DAMAGES.

You agree to fully indemnify TI and its representatives against any damages, costs, losses, and/or liabilities arising out of your non-compliance with the terms and provisions of this Notice.

This Notice applies to TI Resources. Additional terms apply to the use and purchase of certain types of materials, TI products and services. These include; without limitation, TI's standard terms for semiconductor products (<http://www.ti.com/sc/docs/stdterms.htm>), [evaluation modules](#), and [samples](http://www.ti.com/sc/docs/sampterm.htm) (<http://www.ti.com/sc/docs/sampterm.htm>).

Mailing Address: Texas Instruments, Post Office Box 655303, Dallas, Texas 75265  
Copyright © 2017, Texas Instruments Incorporated